



F&F Filipowski L.P.
Konstantynowska 79/81, 95-200 Pabianice, Poland
phone/fax (+48 42) 215 23 83 / (+48 42) 227 09 71
www.fif.com.pl; e-mail: biuro@fif.com.pl

Wireless system
F&Wave

FW-STR1D

Roller-blind controller

230 V AC



5 190831 21599289

Do not dispose of this device to trash with other unsorted waste! In accordance with the Waste Electrical and Electronic Equipment Act any household electro-waste can be turned in free of charge and in any quantity to a collection point established for this purpose, as well as to the store in the event of purchasing new equipment (as per the old for new rule, regardless of brand). Electro-waste thrown in the trash or abandoned in the bosom of nature pose a threat to the environment and human health.



Description of the system

F&Wave is a family of wireless devices controlled by radio with a range of up to 100 meters*. The receivers are available in either a DIN-rail mounting version (housing 1S) or a $\varnothing 60$ flush-mounted version. The transmitters are available as handheld remote controllers or as a flush-mounted version. The receivers relay control signals. The device that receives a control signal from the transmitter will automatically send it forward, which allows to increase the range of the remote control.

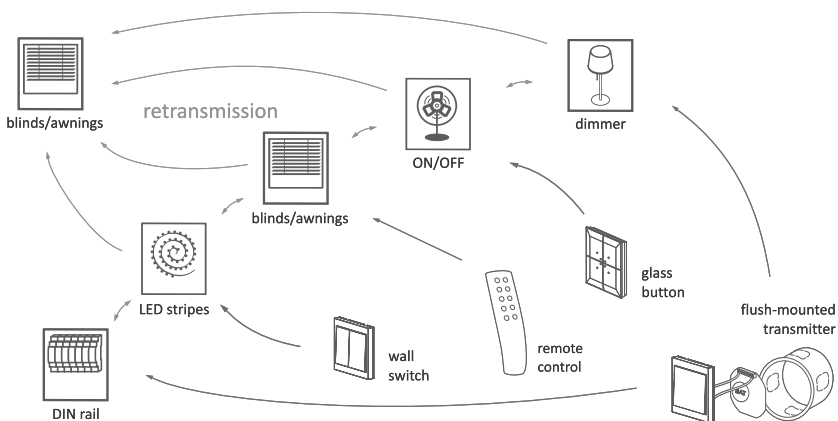

* Range of up to 100 meters in open space without any interfering factors. In building conditions and in the presence of interference sources (power lines, transmitters, etc.) the actual range may be smaller.



Installation of this device should be carried out by a qualified installer after reading this manual. Dismantling the casing of the device will automatically void the warranty. Before starting the assembly, make sure that the connecting wires are not live. Conditions of storage, transport and use affect the proper operation of the device.

Features of the module

- ♦ Controller of the roller-blinds with AC motors;
- ♦ Cooperation with remote control transmitters of the F&Wave system;
- ♦ The ability to control from up to 8 transmitters;
- ♦ 2 inputs for local control - the ability to directly control the relay using any mono-stable button (for example: bell button);
- ♦ 2 output contacts for both directions of the roller-blind movement with a load capacity of 1.5 A (AC-3);
- ♦ Compact enclosure - takes only 1 field in the switchboard;
- ♦ Retransmission of commands from the transmitter - the ability to increase the range of the remote control;
- ♦ Low power consumption - low operating cost;
- ♦ Built-in electronic thermal protection to prevent damage in case of excessive load of the relay;
- ♦ Electric lock to prevent power supply switching on on both windings of the motor.

Description of the device

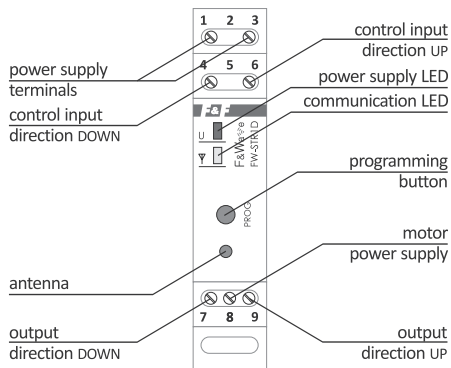

Wiring diagram

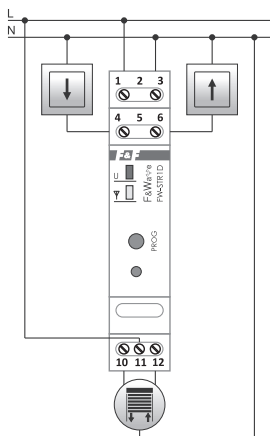

- 1 - L power supply
- 3 - N power supply
- 4 - control input triggered with level L or N - direction DOWN
- 6 - control input triggered with level L or N - direction UP
- 10 - output - direction DOWN
- 11 - motor power supply
- 12 - output - direction UP



Control inputs do not cooperate with backlighted buttons.

Load capacity

1.5 A/250 V (AC-3)

The actual maximum load depends on the nature and design of the receiver.
For more information visit: www.fif.com.pl.

Pairing

①

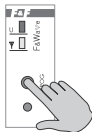

After the device is properly connected, press and hold the PROG button until the relay will switch on and the communication LED will go off.

②

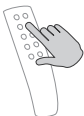

Press the selected button on a remote control or in a flush-mounted transmitter.

③

Correct pairing will be confirmed by temporary switching off of the output circuit and the LED will turn on again.

The remote control is programmed with the roller blind controller on the basis of pairs of buttons. For FW-RC5 and FW-RC10 transmitters the subsequent buttons are paired. For example, if the button "1" on the remote control is paired with the receiver, then for the opposite direction of movement the subsequent button "2" will be automatically paired.

④

For FW-RC4 transmitter are paired buttons that are vertically adjacent. For example, if the button "1" on the remote control is paired with the receiver, then for the opposite direction of movement button "3" will be automatically paired.



The receiver can be paired with 8 different transmitters (remote buttons). Pairing with more buttons will remove the first entries made.

Unpairing

To clear the list of transmitters cooperating with the receiver, press the PROG button and hold it down for at least 10 seconds. Fast flashing of communication LED will indicate that the memory of the controller has been cleared.

Local buttons

Short press of a button activates the roller-blind in the selected direction of movement. Subsequent press during the roller-blind movement causes it to stop.

Long press of a button (for longer than 5 seconds) activates the programming mode of the passage time of the roller-blind.

Passage time programming

The default time of roller-blind passage is 30 seconds.

To change this time you need to:

- ♦ unroll the roller blind to the maximum by pressing the down direction button;
- ♦ when the roller-blind stops, release the down direction button and then press and hold the up direction button of the roller-blind;
- ♦ after 5 seconds the roller-blind will start to roll up, and when it stops in the utmost upper position immediately release the up direction button;
- ♦ time of the roller-blind passage can be adjusted in the range of 5÷120 seconds.

Remote buttons

The FW-RC4, FW-RC10 transmitters operate on the principle of a bistable switch: one press of a button activates the roller-blind in a selected direction of movement, the second press of a button during the movement of the roller-blind causes it to stop.

The FW-RC5 transmitter also has separate inputs ON (always raise the roller-blind) and OFF (always lower the roller-blind).



Due to the nature of transmission and retransmission do not use the same button in transmitter more often than every 2 seconds. Switching of the receiver may be carried out with a short delay.



We do not recommend the use of remote bistable transmitters to control a group of receivers due to the possibility of desynchronization of the activation state (especially when operating on larger distances and/or simultaneous use of local buttons on the receivers).



Activation of the thermal protection is indicated by a steady pulsing of communication LED, switching off of the output circuit and the lack of its reactivation possibility. After lowering the temperature to a safe value the output circuit will remain switched off until restarted.

Devices of the F&Wave system

Battery transmitters

Type	Product
Flood sensor	FW-FS1
Remote control	FW-KEY, FW-RC4, FW-RC10
Wall button	FW-WS1, FW-WS2, FW-WS3
	FW-WSO1, FW-WSO2, FW-WSO4
Flush-mounted box $\varnothing 60$	FW-RC5

AC transmitters

Type	Product
Flush-mounted box $\varnothing 60$	FW-GS1, FW-GS2, FW-GS4
	FW-RC4-AC

Receivers

Function	Flush-mounted box $\varnothing 60$	DIN rail
Correct operation of LED light bulbs with devices of the FW-...-NN series	FW-BYPASS-NN	---
Universal dimmer	FW-D1P	FW-D1D
2-channel LED controller	FW-LED2P	FW-LED2D
Single relay	FW-R1P	FW-R1D
Single multifunction relay	FW-R1P-P, FW-R1-P-NN	FW-R1D-P
Double relay	FW-R2P	FW-R2D
Double multifunction relay	FW-R2P-P, FW-R2P-NN	FW-R2D-P
Roller blind controller	FW-STR1P	FW-STR1D
Roller blind multifunction controller	FW-STR1P-P	FW-STR1D-P

Technical data

power supply	85÷265 V AC/DC
control input	85÷265 V AC; <1 mA
power consumption	
operation mode	1.00 W
standby	0.25 W
output load capacity (AC-1/AC-3)	8 A/1.5 A
radio frequency	868 MHz
maximum emitted frequency power	10 mW
working temperature	-25÷65°C
terminal	2.5 mm ² screw terminals
tightening torque (max)	0.4 Nm
mounting	on TH-35 rail
dimensions	1 module (18 mm)
ingress protection	IP20

Warranty

F&F products are covered by a 24 month warranty from the date of purchase. The warranty is effective only with a proof of purchase. Contact your dealer or directly with us.

CE declaration

F&F Filipowski L.P. declares that the device is in conformity with the essential requirements of Directive 2014/53/EU of the European Parliament and of the Council of 16 April 2014 on the harmonisation of the laws of the Member States relating to the making available on the market of radio equipment and repealing Directive 1999/5/EC. The CE Declaration of Conformity, along with the references to the standards in relation to which conformity is declared, can be found at www.fif.com.pl on the product page.

Compliance with the standards

PN-EN 55024:2011; PN-EN 60669-1:2006;
PN-EN 60669-2-2:2008; PN-EN 62368-1:2015-03;
PN-ETSI EN 300 220-1 V3.1.1:2017-08
PN-ETSI EN 300 220-2 V3.1.1:2017-08
PN-ETSI EN 301 489-1 V2.1.1:2017-08
PN-ETSI EN 301 489-3 V1.6.1:2014-03
E231103