



F&F Filipowski L.P.
Konstantynowska 79/81, 95-200 Pabianice, POLAND
phone/fax (+48 42) 215 23 83 / (+48 42) 227 09 71
www.fif.com.pl; e-mail: biuro@fif.com.pl

BIS-411 1R1Z 24 V

Bistable relay



Do not dispose of this device in the trash along with other waste! According to the Law on Waste, electro coming from households free of charge and can give any amount to up to that end point of collection, as well as to store the occasion of the purchase of new equipment (in accordance with the principle of old-for-new, regardless of brand). Electro thrown in the trash or abandoned in nature, pose a threat to the environment and human health.



Purpose

Electronic bistable pulse relay BIS-411 1R1Z allows switching on or off the lighting or other device from several different points by parallel connected, momentary (bell) control switches.

Functioning

The receiver is switched on after a current pulse caused by pressing any momentary (bell) button connected to the relay. After the next pulse, the receiver will be switched off. The relay does not have a "memory" of the contact position, which means in the event of a power failure and its subsequent return, the relay contact will be set to "off". This prevents the controlled receivers from being switched on automatically without supervision after a prolonged power failure.

Mounting

1. Disconnect the power supply.
2. Fix the relay on a rail in the control box.
3. Connect the power wires to terminals 1-3: for AC voltage, any polarity; for DC voltage: "+" to terminal 3, "-" to terminal 1.
4. Momentary switches connected in parallel, connect to terminal 6 and to the wire to which terminal 3 is connected.
5. Connect the powered receiver in series to terminals 7-9 or 10-12.

Wiring diagram

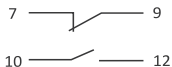
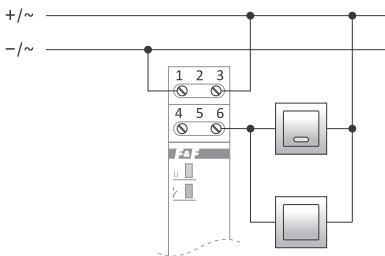



BIS-411 1R1Z can't work with backlit buttons.

- 1-3 power supply of the relay 9÷30 V AC/DC
- 6 control input
- 7-9 output – NC contact (passive)
- 10-12 output – NO contact (active)

Example of connection

Different supply voltages for the relay and receiver

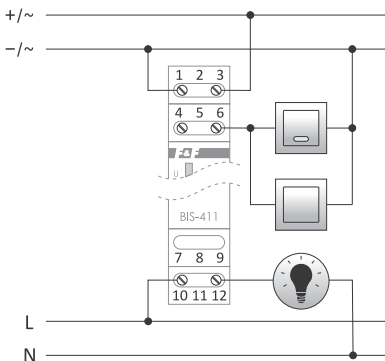







The maximum total backlight current of all connected buttons must not exceed 5 mA.

Technical data

power supply	9÷30 V AC/DC
contact	separated 1×NO, 1×NC
maximum load current (AC-1)	2×8 A
control pulse current	5 mA
activation delay	0,1÷0,2 s
power supply indication	green LED
activation indication	red LED
power consumption	
standby	0.15 W
on	0.6 W
terminal	2.5 mm ² screw terminals
tightening torque	0.4 Nm
working temperature	-25÷50°C
dimensions	1 module (18 mm)
mounting	on TH-35 rail
ingress protection	IP20

Power table

				
tungsten	halogen	fluorescent	energy-saving	LED
1000 W	600 W	500 W	250 W	100 W

The above data are indicative and will heavily depend on the design of a specific receiver (that is especially important for LED bulbs, energy-saving lamps, electronic transformers and pulse power supply units), switching frequency and operating conditions.

For more information visit: www.fif.com.pl.

Warranty

The F&F products are covered by a warranty of the 24 months from the date of purchase. Effective only with proof of purchase. Contact your dealer or directly with us.

CE declaration

F&F Filipowski L.P. declares that the device is in conformity with the essential requirements of The Low Voltage Directive (LVD) 2014/35/EU and the Electromagnetic Compatibility (EMC) Directive 2014/30/UE.

The CE Declaration of Conformity, along with the references to the standards in relation to which conformity is declared, can be found at www.fif.com.pl on the product page.

