



Konstantynowska street
79/81 95-200 Pabianice
tel/fax 42-2152383, 2270971
e-mail: biuro@fif.com.pl

Universal programmable clock

PCZ-528.3

Operating instructions

v. 1.0.1

Safety information regarding the use of the controller is indicated by the following symbols. All information and recommendations marked with these symbols must be strictly adhered to.





	Risk of electric shock.
	Potentially dangerous situation that could lead to danger to operating personnel or damage to the equipment.
Information on the construction, operation and handling of the controller is indicated by symbols:	
	Important information, valuable advice.
	Practical advice, problem solving.
	Example of application or action.

Table of contents

Part 1: Introduction	8
Part 2 Installation	9
Safety measures.....	9
Assembly	9
Load capacity	10
Inrush current limitation.....	12
Use of auxiliary contactor	13
Part 3 Principle of operation	14
Operating modes	14
Automatic mode	14
Programmes	14
Work periods.....	15
Public holidays.....	15
Semi-automatic mode.....	16
Manual mode	16
Part 4 Service.....	17
Display.....	17
Control buttons.....	18
Home screen.....	19
Communications	19
Low battery	19
Faults	20
Relay activation interlock.....	21
Quick access menu	22
Date	22
Current programme	22
Working time statistics.....	25
Manual control	27
Part 5 Configuration	28
Menu structure.....	28

Date.....	29
Time	30
Programmes.....	32
Adding a programme	32
Programme edition	38
Programme deletion	39
Time periods	41
Editing the time period	41
Restore the default time period	44
Public holidays	45
Adding a new public holiday	47
Festive day edition	48
Deleting a public holiday	49
Location	50
Location based on table of localities.....	50
Location based on geographical coordinates	52
Operating mode selection.....	55
System settings	55
PIN security	56
Automatic time change.....	57
Screen backlight.....	58
Backlight in idle state	58
Backlighting in active state.....	59
Display contrast.....	60
Clock calibration.....	61
Limitation of working time	62
Cleaning the settings.....	64
Resetting working time statistics	64
Resetting the operating time limit	65
Deleting all settings	66
Working time history	67
Device information	67

Part 6 Mobile application	68
Home screen	69
New configuration	70
Open configuration	73
My devices	73
Information	74
Device screen	75
About the device	75
Read from PCZ	76
Save to PCZ	77
Read from file	78
Save to file	78
Restore	80
Edition	80
Programmes	82
Period	86
Saints	87
Statistics	88
Location	89
Settings	92
Part 7 List of defined locations	96
Albania	96
Armenia	96
Austria	96
Azerbaijan	97
Belgium	97
Bulgaria	98
Bosnia and Herzegovina	98
Belarus	98
Kazakhstan	99
Kyrgyzstan	100
Switzerland	100

Cyprus	101
Czech Republic	101
Dishes	101
Germany	102
Spain	104
Estonia	106
Finland	106
France	107
United Kingdom	109
Georgia.....	110
Greece.....	110
Croatia.....	111
Hungary.....	111
Ireland.....	112
Iceland.....	112
Italy	112
Lichtenstein.....	114
Lithuania	114
Luxembourg	114
Latvia.....	115
Macedonia	115
Monaco.....	115
Moldova	115
Malta.....	115
Mongolia.....	115
Netherlands	116
Norway.....	116
Poland	117
Portugal.....	119
Romania	120
Russia	120
San Marino.....	122
Serbia	122

Slovakia	123
Slovenia	123
Sweden	124
Tajikistan	125
Turkmenistan	125
Ukraine	125
Uzbekistan	127
Part 8 Technical data	129
Part 9: History of change	130
Part 10 - Guarantee	131
Part 11 CE declaration	132

Part 1. Introduction

The PCZ-528.3 is a universal programmable clock combining the features of an astronomical, weekly and annual clock. Basic features of the clock:





- 256 relay on/off programmes;
- Each programme can be executed in one of the seven date ranges defined in the annual cycle;
- Possibility to enter up to 32 public holidays and select which programmes will be performed on holidays;
- For each of the operating programmes, it can be independently determined whether the programme will be executed in an hourly cycle (fixed hour and minute) or astronomical cycle (linked to the position of the sun in relation to the horizon);
- In each astronomical programme, the switch-on/switch-off offset relative to the selected astronomical point can be set independently (e.g. switch-on one hour before sunset, switch-off two hours after dusk);
- For each programme, you can freely select on which days of the week it will be executed;
- Timer can be programmed using the free PCZ Konfigurator mobile app using the NFC short-range radio communication mechanism ;^(*)
- Possibility to protect the clock settings with a PIN code;
- Advanced runtime counter to measure the switch-on time of the receiver:
 - on the current day and month,
 - per month, over the past 12 months,
 - total from the moment the clock first starts,
- Auxiliary, erasable, timer;
- Possibility of limiting the total switch-on time of the receiver (up to a maximum of 99999 hrs);
- Control input for connection of an external momentary push button;
- Backlit LCD display with adjustable brightness and contrast levels;
- Replaceable battery type 2032 to keep the clock running in the absence of power .^(**)

(*) Remote programming requires an Android phone with built-in NFC support and the free PCZ Konfigurator app (downloadable from the Google Play shop). The NFC communication range is limited to a few centimetres, therefore a direct connection of the phone to the clock is required to transfer the configuration from the application to the clock.

(**) In the event of a power failure, the internal battery only keeps the internal clock running so that the current time and date are not lost. In the event of a power failure, all internal clock functions, such as the display and the relay, remain switched off.





Part 2. Installation

Safety measures

	Installation of the appliance must be carried out by qualified installers with knowledge and experience of electrical installations. Read the instruction manual before installation.	
	All installation work must be carried out with the supply voltage switched off. Careful attention must be paid to the tightening of wires - loose wires can lead to sparks or, in extreme cases, to the appliance catching fire.	

Assembly

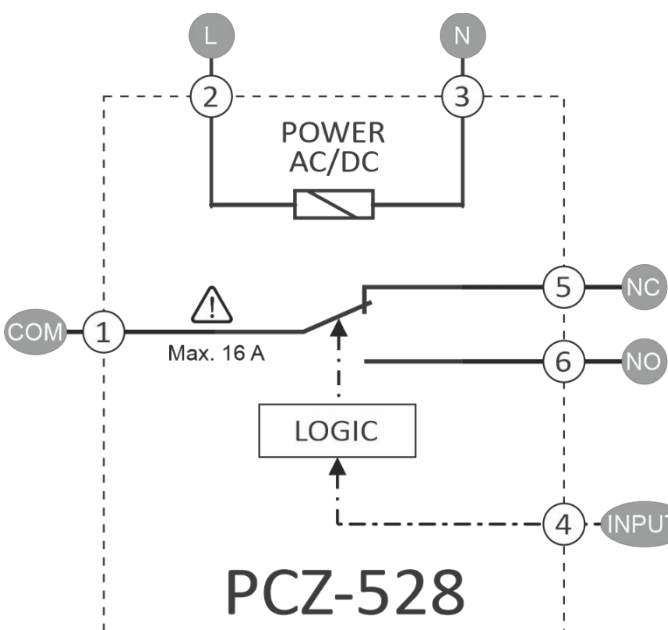
The structure of the PCZ-528 timer is shown in Fig. 1. In order for the timer to operate, it is necessary to connect the power supply to terminals 2 and 3. An example application diagram is shown in Fig. 2.

	It is recommended to protect the clock with a time-delay fuse of 100 mA (for 230V supply) or 250 mA (for 24V supply).	
 <p><i>Figure 1: Schematic diagram of the controller</i></p>		
Controller terminal function		
1	COM	Relay - common contact
2	L	Controller power supply 24 - 265 V AC/DC
3	N	
4	INPUT	Control input Trigger level L/N/+
5	NC	Relay - normally closed contact
6	NO	Relay - normally open contact
	The maximum allowable current flowing through the relay contacts must not exceed 16 A. It is recommended to protect the load circuit of the controller with a fuse with a value adapted to the load current, but not more than 16 A.	

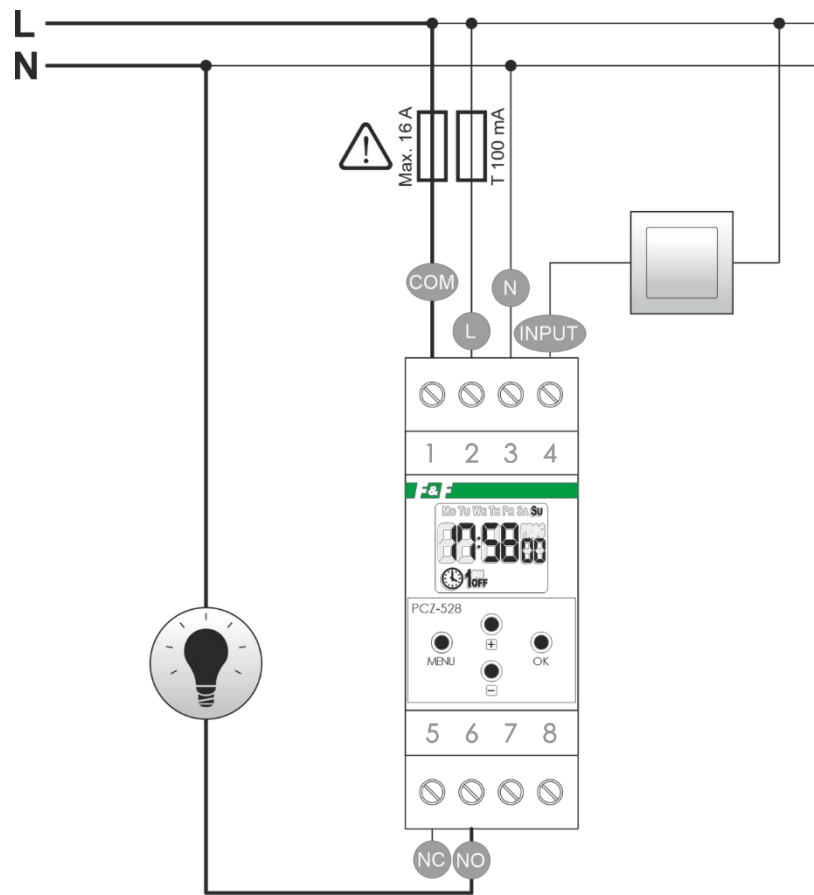





Fig. 2: Example wiring diagram

Load capacity

	The maximum load capacity of the relay contacts depends on the nature of the load and the supply voltage. When installing the controller, please note the indicative load capacity tables below.						
Light source 230 V AC							
	Incandescent	Halogen	Glowing	Energy efficient	LED		
Load capacity (*)	2000 W	1250 W	1000 W	500 W	250 W		
The nature of the burden	Alternating current			Direct current			
	AC-1	AC-3	AC-15	DC-1			
	Non-inductive or resistive load	Rotating induction devices	Variable electromagnetic loads	Load or resistive	Non-inductive		
Voltage	230 V	230 V	230 V	24 V	115 V	230 V	
Load capacity (*)	4000 W	500 W	750 VA	16 A	0.5 A	0.25 A	

	(*) The load capacity tables are indicative and depend on the design of the connected consumer. When selecting the maximum load for a particular type of relay, take into account:		
	Light bulbs	The resistance of a cold bulb is usually at least 10-12 times lower than the resistance of a working bulb. For example, a cold bulb 230V/100W has a resistance of approx. 40 Ohm, which means that, in the worst-case scenario, a current of approx. 5.5 A flows through the bulb when it is switched on for at least a few milliseconds, decreasing to a nominal value of approx. 0.4 A as the bulb warms up.	
	Halogens	As with a normal incandescent bulb, the resistance of a cold halogen bulb is 16-20 times lower than that of a working incandescent bulb. This means that for a 230V/100W bulb a current of 6.5-8 A can flow when the bulb is switched on.	
	Single-phase induction motor (e.g. pump)	The motor starting current can be up to 5-10 times the rated current. In addition, such motors are equipped with additional starting capacitors that can further increase the value of the starting current.	
	Switch-mode power supply (e.g. for LED lighting)	Switch-mode power supplies are fitted to an increasing number of electrical appliances, including LED bulbs, energy-saving bulbs and fluorescent lamp drivers, among others. At the same time, it is the worst possible type of load. This is due to the fact that at the input of such power supplies there are capacitors which, when the power supply is connected, practically constitute a short-circuit - for a few milliseconds currents can flow there with values 100 to 200 times higher than the rated currents of such a supply.	

	If it is necessary to control a load which exceeds the limit load capacity of the relay, one of the following solutions should be used	
---	--	---

Limitation of inrush current

If the rated current of the load is less than the limit current of the relay, the surge currents occurring when the load is switched on can be limited using MST soft-start circuits. An example diagram of such an application is shown in Fig. 3. The MST circuit limits the power supply and current by including an additional NTC resistor in series with the load. After one second, the NTC element is disconnected and full power is transferred to the receiver.

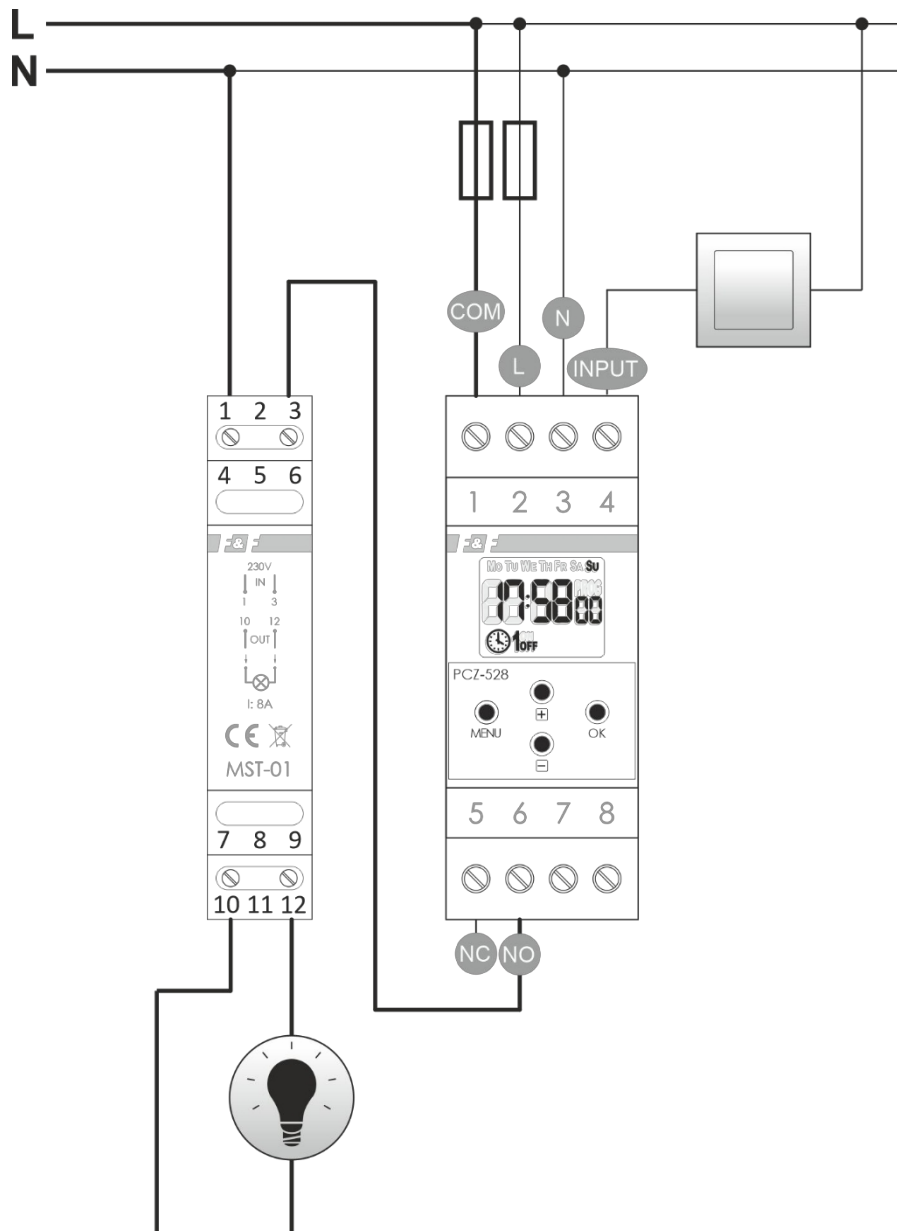

Fig. 3: Use of soft-start circuit to limit starting current

When the rated current does not exceed 8 A, the **MST-01** or **MST-02** arresters can be used. When the rated current exceeds 8 A but does not exceed 16 A, the **MST-03** arrester must be used.

Use of auxiliary contactor

When the current of the load exceeds 16 A, the only possibility of controlling such a load is to use an auxiliary contactor switched by the relay contacts of the PCZ timer. An example of such a circuit is shown in Fig. 4.

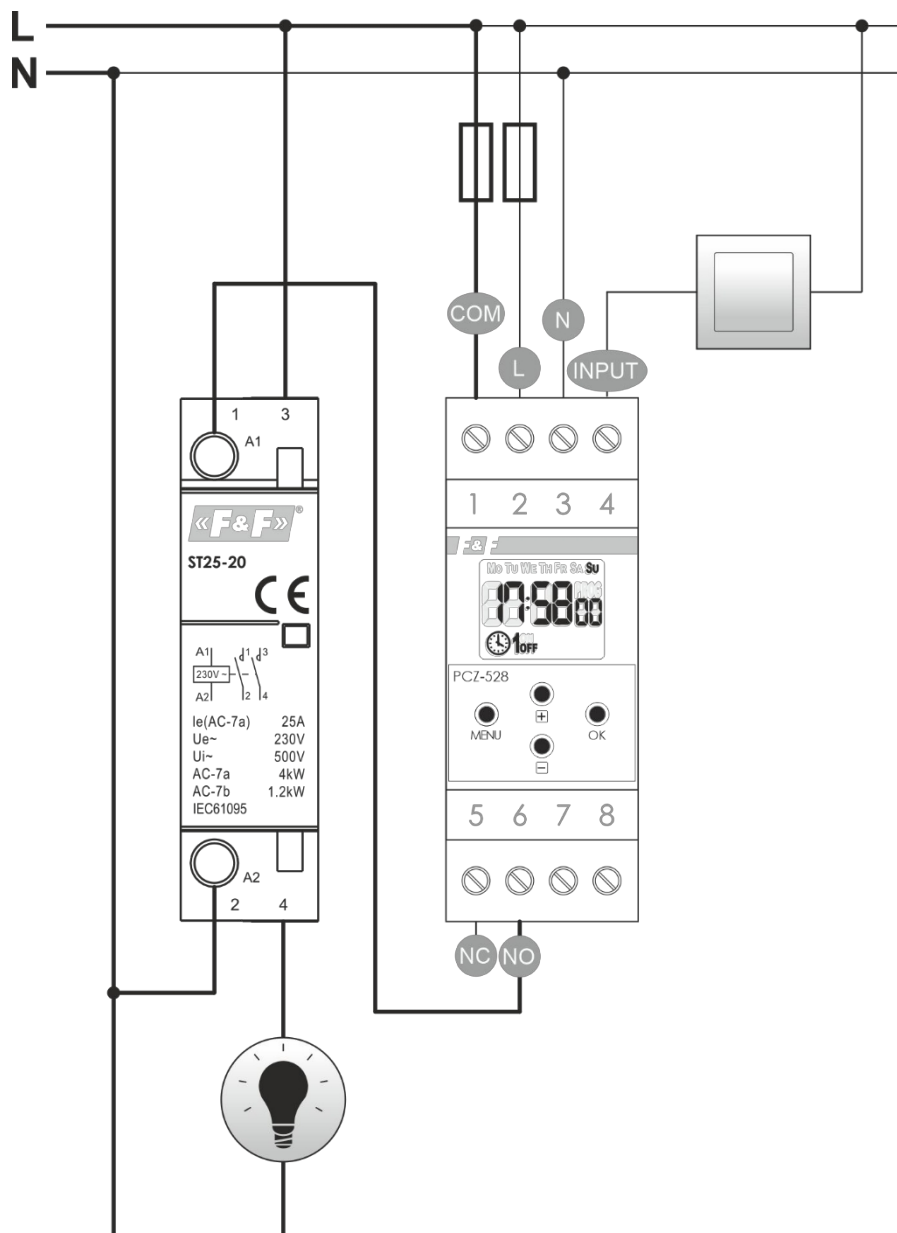

Figure 4: Use of a contactor to control high power circuits

Part 3. Operating principle

Modes of operation

The PCZ-528 controller can operate in one of three operating modes.

Automatic mode

Operation in automatic mode consists of automatic processing of all programmes stored in the controller's memory.





Programmes



Each programme includes information on:

- The period of time during which the programme will be executed. The period can be either a date range (start date - end date) or holidays based on a list entered by the user;
- The days of the week on which the programme will be performed;
- The time when the programme starts. The time can be either a specific time or a moment based on astronomical points (sunset, sunrise, dawn, dusk);
- Relay action (on or off).

How to enter and manage the programme list is described in more detail on page 32

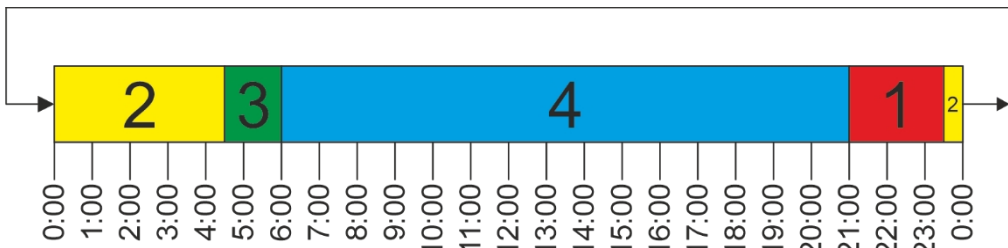

The controller sets the programmes in a chronological order (independent of the order in which the programmes are stored in the controller's memory), and then selects the programme which will be executed at a given moment. A given program will be executed until the next program starts.

	Programm e 1		The programme switches on the relay every weekday at 9 p.m.	
	Programm e 2		The programme switches off the relay every weekday at 11:30 p.m.	

<p>Programm e 3</p>		<p>The programme switches on the relay every weekday at 4:30 a.m.</p>
<p>Programm e 4</p>		<p>The programme switches off the relay every weekday at 6:00 a.m.</p>
<p>For a programme list defined in this way, the daily programme execution sequence is shown in the diagram below.</p> 		

Work periods





For each programme, a period of time must be set in which it will be executed. The period is defined as the time interval between the start date (day and month) and end date entered by the user.

	<p>Example: Two working periods are introduced: Period 1) 01 January - 31 December, Period 2) 15 March - 15 September. Programmes assigned Period 1 will run throughout the year. Programmes which are assigned Period 2 will run from 15 March to 15 September (inclusive) - outside this period, the programme will be ignored.</p>	
---	--	---

Creating and editing work periods is described in more detail in the chapter on date ranges (page 41), and how to link programmes to work periods is described in the **Programmes** chapter on page 32.

Festive days





The PCZ_528 controller allows special days (holidays) to be programmed, during which programmes intended exclusively for holidays will be executed.

	<p>Holidays have priority over other time periods. This means that if a day is listed as a holiday, only programmes intended for holidays can be executed on that day.</p>	
	<p>Example: Two operating programmes are entered in the controller: Programme 1 - turn on the lights at 22:00, all days of the week, from 1 January to 31 December; Programme 2 - switch off lights at 22:00, on public holidays The list of public holidays includes 1 and 3 May. In this case, they will perform on consecutive days:</p> <ul style="list-style-type: none"> 1 May - Programme 2 (Programme 1 will be omitted as it does not apply to public holidays). 2 May - Programme 1 (Programme 2 will be omitted as 2 May is not on the list of public holidays) 3 May - Programme 2 (Programme 1 will be omitted as it does not apply to public holidays). 	

Creating and editing the list of public holidays is described in the section **Holidays** on page 45.

Semi-automatic mode

Semi-automatic mode means temporary interruption of the automatic mode and the possibility of manual switching of the relay contact to the opposite position. The timer operation in the semi-automatic mode is signalled by blinking the clock face on the controller display. The semi-automatic mode is interrupted when the next operating programme is activated, after which the controller returns to the automatic mode.

	<p>Switching from automatic to semi-automatic mode is carried out by briefly pressing the + or - button on the facade of the controller, or an external momentary button connected to the controller. Another pressing of the button restores the automatic mode.</p>	
	<p>Example: Two operating programmes are set up in the controller: the first, with the command to switch on the light at dusk, and the second, with the command to switch off the light at dawn. At dusk, the light was switched on and the user pressed a button. This caused the light to switch off and switch to semi-automatic operation. At dawn the next day, another programme started and the controller returned to automatic operation. Therefore, in the evening the light will switch on again according to the programme.</p>	

Manual mode

In manual mode, the list of programmes stored in the controller's memory is ignored and switching on/off is performed manually by the user. In manual mode, the relay status can be changed by briefly pressing the +/- button on the controller facade or an external momentary button connected to the timer control input.

Part 4. Handling

Display

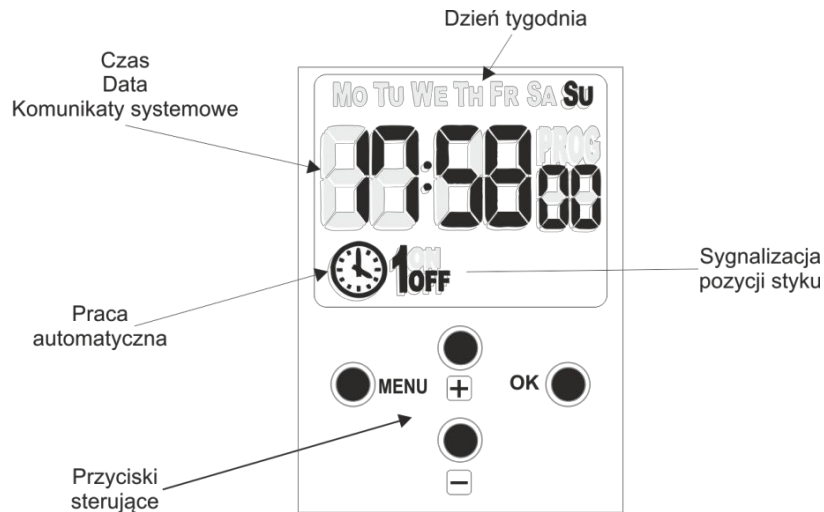

Fig. 5: Timer control panel

Where:







Day-of-the-week designations:

Mo - Poniedziałek
TU - Wtorek
WE - Środa
TH - Czwartek
FR - Piątek
SA - Sobota
SU - Niedziela

Mode indication:

	Automatic mode - relay off
	Automatic mode - relay on
	Semi-automatic mode - Relay on
	Semi-automatic mode - relay off
	Manual mode - relay off
	Manual mode - relay on
Black	Display segment on
Red	Blinking display segment

Control buttons

<p>MENU</p>	<p>Pressing the button enters the controller's configuration mode. In Parameter edit mode, pressing Menu drops the parameter being edited (without storing the changes made) and returns to the parent menu level.</p> <table border="1" data-bbox="354 398 1458 725"> <tr> <td data-bbox="354 398 480 725">  </td> <td data-bbox="480 398 1334 725"> <p>If PIN protection has been activated on the clock, a valid 4-digit PIN must be entered after pressing the Menu button.</p> <p>If the PIN code is entered, the control unit may be operated freely. In the event of user inactivity, if no button is pressed for 60 seconds, the controller returns to secured mode.</p> </td> <td data-bbox="1334 398 1458 725">  </td> </tr> </table>		<p>If PIN protection has been activated on the clock, a valid 4-digit PIN must be entered after pressing the Menu button.</p> <p>If the PIN code is entered, the control unit may be operated freely. In the event of user inactivity, if no button is pressed for 60 seconds, the controller returns to secured mode.</p>	
	<p>If PIN protection has been activated on the clock, a valid 4-digit PIN must be entered after pressing the Menu button.</p> <p>If the PIN code is entered, the control unit may be operated freely. In the event of user inactivity, if no button is pressed for 60 seconds, the controller returns to secured mode.</p>			
<p>OK</p>	<p>In edit mode, pressing the button moves to editing the next setting item. If the last item is being edited, pressing the OK button saves the new value of the parameter, exits the edit mode and goes to the higher menu level.</p> <p>In the time display mode, pressing the OK button will display a quick access menu allowing you to view information about the current date, the levels of the currently executing programme and access time statistics.</p>			
<p>+ (Top)</p>	<p>In edit mode, pressing the button increases the value of the edited parameter by 1. If the button is pressed for a long time, the parameter value will cyclically increase by 1.</p> <p>In manual operation mode, pressing the button will permanently switch the contact (ON -> OFF or OFF->ON).</p> <p>In automatic mode, pressing the button switches between automatic and semi-automatic mode.</p>			
<p>- (Bottom)</p>	<p>In edit mode, pressing the button reduces the value of the edited parameter by 1. If the button is pressed for a long time, the value of the parameter will cyclically decrease by 1.</p> <p>In manual operation mode, pressing the button will permanently switch the contact (ON -> OFF or OFF->ON).</p> <p>In automatic mode, pressing the button switches between automatic and semi-automatic mode.</p>			

Home screen

The main screen includes information about the current time, day of the week, operating mode and status of the output relay.





Fig. 6: Basic view

Communications

In special cases, the display of the current time and the status of the clock (Fig. 6) may be interrupted by messages indicating low battery levels or a fault in the controller.





Low battery

	<p>A low battery level is not an obstacle during normal clock operation. On the other hand, if the clock is not powered, it can lead to loss of date and time settings. It can also lead to incorrect recording of operating time statistics.</p> <p>NOTE: All settings, except time and date, are stored in non-volatile memory and are not lost in the event of power failure and low battery levels.</p>	
---	--	---

	<p>Low battery message indicates progressive battery discharge. The battery level is low, but is still sufficient to keep the clock running in the event of brief power failures.</p> <p>If such a message is observed, it is recommended to replace the battery with a new one.</p>
---	---



	<p>The Empty batt message indicates a completely discharged or damaged battery. In this case, there is no guarantee that the clock will continue to operate in the event of even a short power failure.</p> <p>If such a message is observed, it is recommended to replace the battery with a new one immediately.</p>
---	--

The PCZ-528 timer uses a 2032-type pastebord battery to support its operation. To replace the battery, disconnect the timer from power supply and remove it from the switchgear. Then disassemble the casing, remove the battery from its socket located on the side plate of the controller, and install a new one in its place.





	<p>The direction of battery insertion is very important - the positive terminal of the battery must be on the upper side of the socket. Reverse battery connection may damage the controller.</p>	
	<p>You can see how to change the battery in a Youtube.com video courtesy of the VTEKA.PL channel.</p> <p>https://www.youtube.com/watch?v=m9Pp0zMZV-8&t=2s</p>	 

Faults

Err messages indicate malfunction or damage of the controller. In the event of an error, it is recommended to switch the power off and on, and then to restore the controller to factory settings.

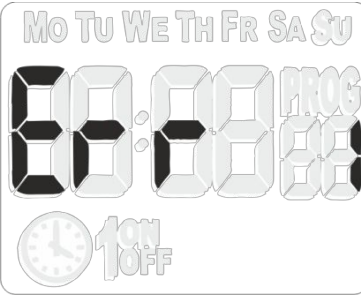
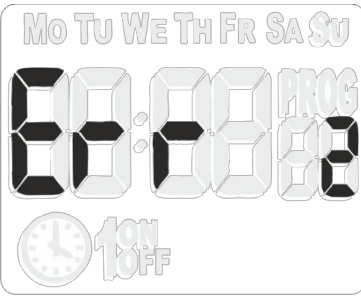
	<p>If the error messages persist or are repeated, it is advisable to contact F&F service. Contact:</p>		
	Phone	E-mail	
	+48 (42) 214 90 37, +48 (42) 215 23 83	dztech@fif.com.pl	



Error codes

	<p>Indicates an error in communication with the external memory of the settings. Lack of connection with the external memory may result in incorrect transmission of the configuration between the mobile application and the controller.</p>	
	<p>Internal data memory error indication. If the external data memory is corrupted at the same time, such an error can lead to a loss of the controller's settings.</p>	
	<p>Temperature sensor error. The temperature sensor is used to co - reate the operating frequency of the quartz generator as a function of temperature. Its failure can lead to a reduction in timekeeping accuracy.</p>	
	<p>If several errors occur at the same time, the Err code will indicate a number which is the sum of the active error codes.</p>	

Relay activation interlock



The relay energising interlock is activated when the pre-set operating time limit is exceeded. When the interlock is activated, the relay remains in the de-activated state, irrespective of the programmer and manual control settings. The interlock is signalled by alternate illumination of the 1 and OFF symbols in the main clock view.



	<p>Unlocking the operation of the controller requires increasing the value of the operating time limit (menu Syst → Limit, page 60), or clearing the current operating time limit counter (menu Syst → Clear → Hist, page 65)</p>	
---	--	---

Quick access menu

The quick access menu allows you to view information about the current date, details of the programme you are currently running and access to working time statistics. To open this menu, press the **OK** button from the main screen.

	The quick access menu can also be called up if access to non-fixed settings is protected by a PIN number.	
---	---	---

The **Up** or **Down** keys can then be used to navigate through the menu items. You confirm your selection and switch to the associated submenu by pressing the **OK** button.

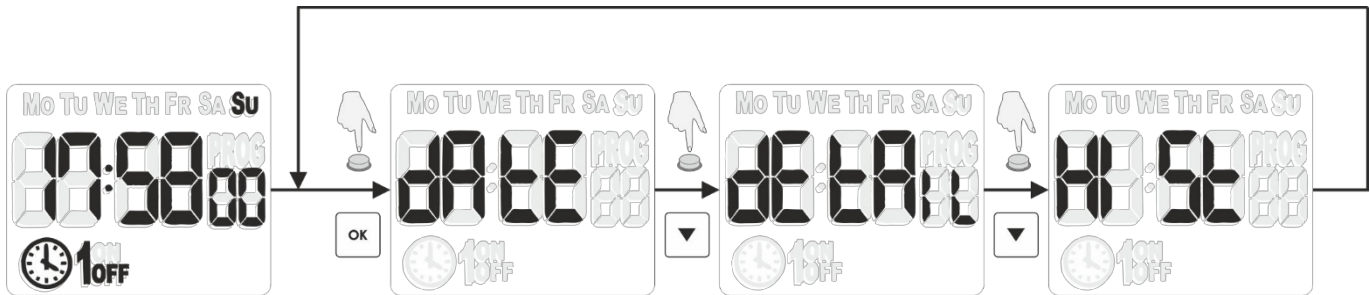



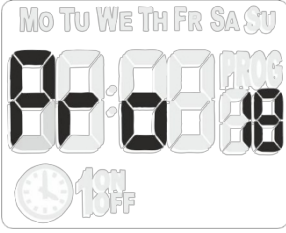
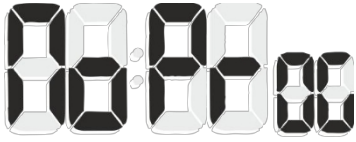



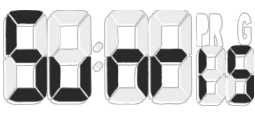
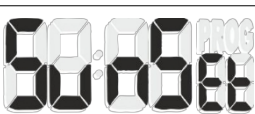

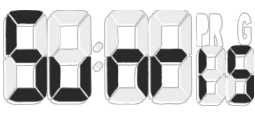
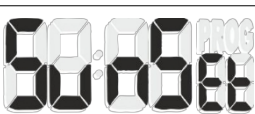

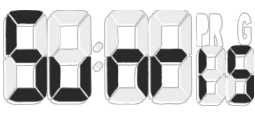
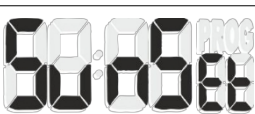





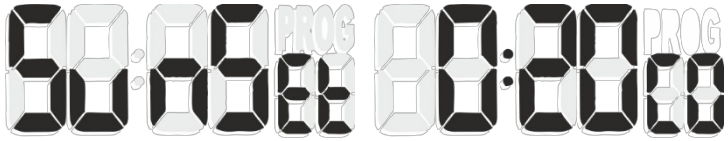



Figure 7: Quick menu structure

	Date
	The Date menu displays the current date set in the clock, in the order day - month - year (small digits). The day indicator at the top of the display indicates the current day.
	Current programme
This view provides detailed information on the programme currently being executed. The values displayed here depend on the current operating mode and the programme being executed.	
Manual mode	
	In manual mode, only one screen with information on the operating mode is displayed.

Automatic mode











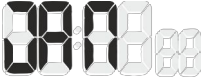





In automatic mode, the display cycles through the screens providing information on the actually executed programme:



<p>1</p>		<p>Number of the currently executed programme. If the current programme is running in time mode (fixed hour and minute on/off), screen number 2 will be displayed. If the programme is running in astronomical mode, screens 3a and 3b will be displayed.</p> <p>If the controller is set in automatic mode, but no programmes have been entered into memory, or no programme can execute on a given day, a message about no programme will be displayed on the screen.</p> 												
<p>2</p>		<p>Details of the programme executed in timed mode. The top row indicates the days of the week on which the programme will be executed, the middle row indicates the hour and minute of the start of the programme's execution, and the bottom row indicates the executed relay action (ON - relay on, OFF - relay off).</p>												
<p>3a</p>		<p>Details of the programme executed in the astronomical mode (first part). The top line shows the days of the week on which the programme will be executed. The central part of the screen shows information about the astronomical point at which the programme will start. The following messages may appear here:</p> <table border="1" data-bbox="483 1417 1474 1939"> <tr> <td></td> <td>Dawn</td> <td>Dawn</td> </tr> <tr> <td></td> <td>Sunrise</td> <td>Sunrise</td> </tr> <tr> <td></td> <td>Sunset</td> <td>Sunset</td> </tr> <tr> <td></td> <td>Twilight</td> <td>Twilight</td> </tr> </table> <p>Note: The exact moment when the programme starts is indicated on the basis of the combination of information from screens 3a and 3b.</p>		Dawn	Dawn		Sunrise	Sunrise		Sunset	Sunset		Twilight	Twilight
	Dawn	Dawn												
	Sunrise	Sunrise												
	Sunset	Sunset												
	Twilight	Twilight												

		<p>The lower part of the display indicates the action of the relay performed in the given program (ON - relay on, OFF - relay off)</p>
3b		<p>Details of the programme executed in astronomical mode (second part). The upper and lower parts of the screen repeat the information from screen 3a. The central part of the screen contains information about the offset (in hours and minutes) of the start time of the programme execution with respect to the astronomical point shown on screen 3a.</p> <div style="display: flex; justify-content: space-between; align-items: center;"> <div style="text-align: center;">  </div> <div style="flex-grow: 1;"> <p>Example</p> <p>The combination of the two messages below means that the execution of the programme will start twenty minutes after sunset. If the offset value has a minus sign, it means that the execution of the command will start a set time before the set astronomical point.</p> </div> <div style="text-align: center;">  </div> </div> <div style="text-align: center; margin-top: 20px;">  </div>
4a		
4b		<p>Start of the time period (day and month) in which the programme will be executed</p>
4c		

4d		End of the time period (day and month) in which the programme will be executed.		
			The example in screens 4a - 4d indicates that the programme in question will be executed between 15 March and 15 September, on the days and at the times indicated in screens 2 and 3.	
5		If this view appears instead of screen 4a, it means that the current day has been set as a public holiday and the programme for the holiday is executed.		



	<h3>Working time statistics</h3>		
<p>The operating time statistics menu allows you to monitor the time for which the relay and the load it controls were switched on. Use the Up or Down buttons to select a parameter and, after pressing the OK button, the recorded operating time for the period will be displayed.</p>			
	<p>Resetting operating time statistics can be done via menu Syst → Clear → Hist (p. 64).</p>		
	<p>Time the relay was switched on for the current day, displayed as hours - minutes - seconds. The daily statistics are reset at 0:00 or when the date changes on the clock.</p>		
	<p>Time the relay was switched on in the current month. The time is displayed as the number of complete hours the relay has been switched on. Zeroing of the monthly statistics takes place on the first day of the month, or if the month has also changed due to a date change.</p>		
	<p>Total time the relay was switched on. The time is displayed as the number of complete hours for which the relay was switched on.</p>		
	<p>Auxiliary counter for the relay switching time. The time is displayed as the number of complete hours the relay has been switched on.</p>		
		<p>The auxiliary switch-on timer can be reset by long-pressing the OK button while the counter value is displayed.</p>	

	<p>Time the relay was switched on in January, displayed as the number of full switching hours.</p>
	<p>Time the relay was switched on in February, displayed as the number of full switch-on hours.</p>
	<p>Relay switch-on time in March, displayed as number of full switch-on hours.</p>
	<p>Time the relay was switched on in April, displayed as the number of full switching hours.</p>
	<p>Relay switch-on time in May, displayed as number of full switch-on hours.</p>
	<p>Time the relay was switched on in June, displayed as the number of full switching hours.</p>
	<p>Relay switching time in July, displayed as the number of full switching h o u r s .</p>
	<p>Time the relay was switched on in August, displayed as the number of full switching hours.</p>
	<p>Relay switch-on time in September, displayed as number of complete switch-on hours.</p>
	<p>Relay switch-on time in October, displayed as number of full switch-on hours.</p>
	<p>Time the relay was switched on in November, displayed as the number of full switching hours.</p>
	<p>Time the relay was switched on in December, displayed as the number of full switch-on hours.</p>
	<p>If the controller is set to limit the maximum operating time, Limit indicates how much time is left before the protection is tripped. The last 24 hours are indicated in the form of the number of hours and minutes remaining, when the remaining time is longer than 24 hours, the result is indicated in the form of the number of hours.</p> <div data-bbox="424 1697 1410 1895" style="border: 1px solid black; padding: 5px; margin-top: 10px;"> <div style="display: flex; align-items: center; justify-content: space-between;"> <div style="text-align: center;">  </div> <div style="text-align: center;"> <p>If the operating time limit is not set in the controller, a message is displayed:</p>  </div> <div style="text-align: center;">  </div> </div> </div>

		<p>A message will be displayed when the set operating time limit is reached:</p>	
			

Manual control

The relay output can be switched using the momentary pushbutton connected to terminal 4 of the timer, or using the **Up** and **Down** buttons on the façade of the controller.

	<p>The Up and Down buttons only allow the relay status to be changed when the main screen is displayed on the clock (Fig. 6).</p>	
---	---	---



The local control buttons perform the following functions:

Button	Manual mode	Automatic mode
Top / Bottom	Pressing the button will permanently switch the contact (ON -> OFF or OFF→ON). The current status of the relay is indicated by the symbol on the display: ON - relay on, OFF - relay switched off	Pressing the button switches between automatic mode (page 14) and semi-automatic mode (page 16).
Input		<p>Briefly press the button to switch between automatic mode (page 14) and semi-automatic mode (page 16).</p> <p>A long press of the button requires the controller to return to automatic mode.</p>

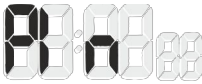
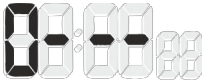
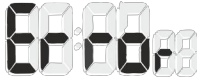

Part 5 Configuration

Configuration of the PCZ-528 timer can be carried out both directly, using the buttons on the facade of the timer and relying on the messages shown on the display, as well as with the help of a mobile application available for phones running the Android system and equipped with an NFC communication module.

In the case of direct configuration, the settings are accessed by pressing the button **MENU**.

	<p>If the timer has the option to secure access to the settings enabled, a prompt will appear asking for the entry of a PIN access code when the MENU button is pressed.</p> <p style="text-align: center;"></p> <p>Followed by a field to enter the PIN number:</p> <p style="text-align: center;"></p> <p>Use the Up or Down keys to set the correct value for the number PIN digit. Move to the next digit by pressing the OK button. Returning to the editing of the previous digit is achieved by pressing the MENU button.</p> <p>After entering and confirming (OK) the last digit of the PIN number, the PIN number is verified. If the PIN number is correct, access to the clock settings is temporarily unlocked. If the PIN number is entered incorrectly, an error message will be displayed.</p> <p style="text-align: center;"></p>	
--	--	--

Menu structure

No	Menu	Function	Website
1		Setting the current clock date	Page 29
2		Setting the current clock time	Page 30
3		Adding, deleting and editing timer programmes.	Page 32













4		Setting date ranges for which programmes will be executed	Page 41
5		Management of the list of (special) holidays	Page 45
6		Setting the geographical location of the clock.	Page 50
7		Clock mode selection	Page 55
8		System settings	Page 55
9		Working time statistics	Page 67
10		Clock information	Page 67

	Date
--	-------------

The **Date** menu allows the current date to be set on the clock. The date is displayed on the screen in day - month - year order, while editing is done in reverse order: year - month - day. The day of the week indicator is updated automatically based on the current date setting.

The date setting scheme is shown in the table below.

	In the timer, the currently edited value is signalled by blinking param- tru digits. In the following, the edited value is signalled in red.		
1		Press the Menu button, then use the Up or Down buttons to display the Date menu.	
2		Press the OK button to enter date edit mode. The digits on the years position will start blinking.	















3		<p>Use the Up and Down buttons to set the correct year.</p>	
4		<p>Pressing the OK button confirms the year and moves on to editing the month</p>	
5		<p>Use the Up and Down buttons to set the correct month</p>	
6		<p>Pressing the OK button confirms the month and moves on to editing the day.</p>	
7		<p>Use the Up and Down buttons to set the correct day</p>	
8		<p>Pressing OK confirms the new date and returns to the Date menu. Note: The day of the week indicator is updated continuously as the years, months and days change.</p>	

	<h2 style="margin: 0;">Time</h2>
---	----------------------------------

The Time menu allows you to set the current time in the clock. The time is set in the form of hours and mi- notes. The seconds counter is automatically set to zero when a new

time. The day of the week indicator is updated automatically based on the current date setting.

The time setting scheme is shown in the table below.







	<p>In the timer, the currently edited value is signalled by blinking param- tru digits. In the following, the edited value is signalled in red.</p>		
1		<p>Press the Menu button, then use the Up or Down buttons to display the Hour menu.</p>	
2		<p>Press the OK button to enter the time edit mode. The digits on the hour position will start blinking.</p>	
3		<p>Use the Up and Down buttons to set the desired time.</p>	
4		<p>Press the OK button to confirm the new time and move on to editing the minutes</p>	
5		<p>Use the Up and Down buttons to set the desired minute.</p>	
6		<p>Pressing the OK button confirms the new time and returns to the Hour menu display.</p> <p>Note: The seconds counter starts counting from zero when the OK button is pressed to confirm the new time.</p>	













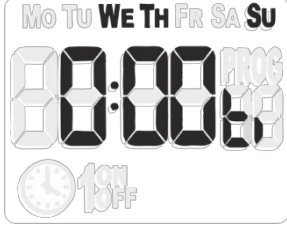
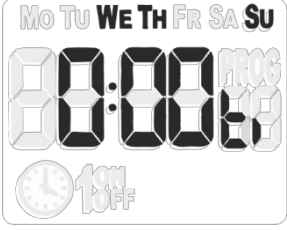

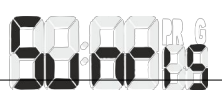
Programmes



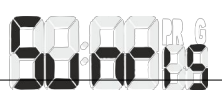

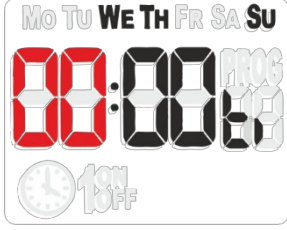

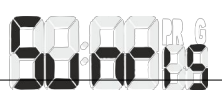

The programmes determine the behaviour of the controller operating in automatic mode. For further information on the logic behind the operation and processing of the programmers, please refer to page 14. The menu for managing operating programmes consists of three items:

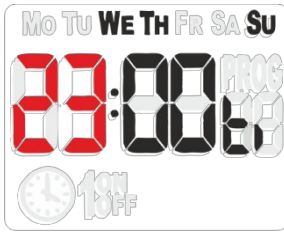



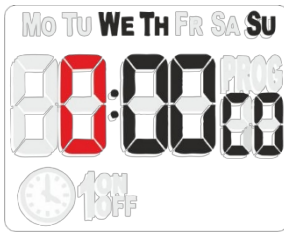





No	Menu	Function	Website
1		Adding new programmes.	Page 32
2		Editing an existing programme.	Page 38
3		Deletion of an existing programme.	Page 39

















		Adding a programme	
1		Press the Menu button, then use the Up or Down buttons to display the Prog menu.	
2		Press the OK button - the message Add will appear on the screen.	
3		Another press of the OK button will start the procedure for adding another program. Note: The controller memory can store up to 256 programmes. When the memory is full, any attempt to add another programme will be rejected and a message about the full memory will be displayed.	



			
4		<p>The screen (left) now shows at which position in the program table the new programme will be stored. The controller automatically substitutes the number of the first free memory cell here.</p> <p>Note: The programme number is information and is not related to the order in which the programmes are executed.</p> <p>After pressing the OK button, the programme moves on to setting the days of the week on which the programme is to be executed.</p>	
5		<p>The upper part of the display shows the days of the week on which the programme will be executed (the example in the picture on the left indicates that the programme will be executed on all days of the week). If the programme is to be executed on days of the week other than the set days, press the OK button and proceed to the configuration of days (point 6). If the day settings are correct, you may skip this step by pressing the Up button and proceed directly to the time setting (point 9).</p>	
6		<p>Editing the days of program execution involves selecting each day of the week on which the program will be executed. The sequence starts with Monday (Mo) - use the Up or Down button to indicate whether the programme will be executed on that day of the week.</p> <p>On - the programme will be executed on the selected day.</p> <p>OF - the programme will not be executed on the selected day.</p> <p>The setting for the edited day is confirmed by pressing the OK button and the programme proceeds to edit the settings for the next day of the week. Pressing the Menu button takes the programme back to the previous editing step.</p>	

7		<p>In the same way, you should decide to act on the other days of the week. The list of active days is continuously updated on the day indicator at the top of the screen.</p>									
8		<p>After confirming the settings for the last day of the week (Su - Sunday) with the OK button, the programme proceeds to the display of the programme start-up time.</p>									
9		<p>The screen on the left indicates the days of the week and when the programme starts. Depending on the setting, the date and time of the programme's start-up, e.g. 11:30 p.m., will appear in the central part of the screen:</p> <p style="text-align: center;">  </p> <p>Or the astronomical moment (linked to the position of the sun relative to the horizon) at which the programme will start.</p> <table border="1" data-bbox="566 1142 1085 1601"> <tr> <td></td> <td>Dawn</td> </tr> <tr> <td></td> <td>Sunrise</td> </tr> <tr> <td></td> <td>Sunset</td> </tr> <tr> <td></td> <td>Twilight</td> </tr> </table> <p>Press the OK button to move on to editing the time. If the time is set by law, you can skip this step by pressing the Up button and moving on to step 19.</p>		Dawn		Sunrise		Sunset		Twilight	
	Dawn										
	Sunrise										
	Sunset										
	Twilight										

10		<p>In the first step, use the Up or Down buttons to set the time, or to wash the astronomical switching point.</p> <p>Note: The astronomical points corresponding to dawn, sunrise, sunset or dusk appear in the list between 23 and 0 o'clock.</p> <p>After confirming this step (OK button), the program proceeds to edit the minutes (step 11) - if a specific time is set here. Or to shift the switching time (step 12) - if an astronomical point has been set.</p>	
11		<p>Use the Up or Down buttons to select the minute the programme starts and confirm the selection by pressing the OK button.</p> <p>After confirming the minute, the programme moves to step 19</p>	
12		<p>Once an astronomical point has been selected and confirmed (OK button), the programme moves on to the option of setting the offset of the switching moment from the selected astronomical point.</p>	
15		<p>Correction C0 enables acceleration (negative value) or deceleration (positive value) of the switching moment in relation to a pre-set astro- nomic point.</p> <div style="border: 1px solid black; padding: 5px; margin-top: 10px;"> <p> Example: Selecting the Sunset setting and setting the C0 correction to - 0:45 will mean that this pro- gram will start 45 mi- notes before sunset</p> </div> <div style="border: 1px solid black; padding: 5px; margin-top: 10px;"> <p> The C0 correction can be made in the range of -4...+4 hrs.</p> </div> <p>In this step, using the Up button or Down, set the number of corking hours.</p>	







		correction. If the correction will be less than a full hour, set -0 for acceleration, or 0 for deceleration.	
16		The selection of the correction in hours is confirmed by pressing the OK button, followed by a transition to setting the number of minutes.	
17		Use the Up or Down buttons to set the desired number of minutes.	
18		The OK button confirms the correction value and the programme proceeds to the selection of the time interval over which the programme will be executed.	
19		<p>The PCZ-528 controller enables the definition of seven independent time intervals in the annual cycle. The Per parameter allows selecting in which of these intervals a given programme step will be performed.</p> <div data-bbox="571 1317 1091 1469" style="border: 1px solid black; padding: 5px;">  How to set the time intervals is described on page 41. </div> <p>The programme can also be executed only on public holidays - to do so, set the Per parameter to HO.</p> <div data-bbox="571 1612 1091 1971" style="border: 1px solid black; padding: 5px;">  A program set to run on holidays (HO) will only run on days in the Holidays list. The handling of the holiday list is described on page 45. In order to edit the selected compartment, press the OK button, which will switch </div>	



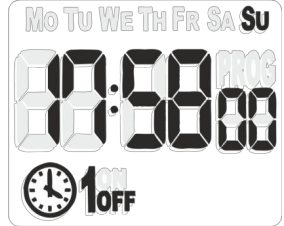

		If the interval is set correctly, you can press the OK button and proceed to setting the transmitter action (step 22).					
20		Use the Up or Down keys to select the time period in which the programme will run. If the programme is to be executed on public holidays, select HO .					
21		Pressing the OK button confirms the setting and takes you to the setting of the relay action implemented by the programme.					
22		<p>Selection of the relay action in a programme step. The action indicator is shown at the bottom of the display:</p> <table border="1" data-bbox="571 996 1086 1220"> <tr> <td></td> <td>Switching off the relay</td> </tr> <tr> <td></td> <td>Switching on the relay</td> </tr> </table> <p>To change the relay action, press the OK button. If the action is set correctly, you can skip this step by pressing the Up button and go directly to step 25.</p>		Switching off the relay		Switching on the relay	
	Switching off the relay						
	Switching on the relay						
23		Use the Up or Down buttons to set the correct action to be performed by the relay in a given step.					
24		Confirm the new setting by pressing the OK button.					

25		<p>The last step (Save) consists in saving the programme entered in the previous steps to the controller's memory. Saving program to memory is performed after pressing OK button. After adding a program, the controller automatically proceeds to adding another program. Pressing the OK button again initiates the procedure described in steps 3-24 for the next program.</p> <p>Pressing the Menu button exits the mode for adding another programme and returns to the previous menu.</p>	
----	---	--	---

	<h2>Programme editing</h2>
---	----------------------------







This menu is designed for editing programmes already entered into the controller's memory.



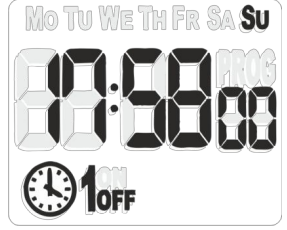





1		<p>Press the Menu button, then use the Up or Down buttons to display the Prog menu.</p>	
2		<p>Press the OK button - the message Edit will appear on the screen.</p>	
3		<p>Pressing the OK button again will display the number of the first program in the controller's memory.</p> <p>Note: If no programme has been written in the controller's memory, a message will be displayed:</p> 	

4		<p>Use the Up or Down buttons to select the programme to edit.</p> <p>Note: Seconds after changing the program number, details of the edited programme appear on the screen.</p>	
5		<p>The upper part of the screen displays days when the programme will be executed, four large digits in the central part of the screen indicate the time when the command will be executed, two small digits in the central part of the screen indicate the time interval when the command will be executed. The On or Off symbol in the lower part of the screen indicates whether the command will switch the relay on or off.</p> <p>Pressing the OK button starts programme editing. Editing a programme follows the same steps as for adding programmes.</p>	

	<h2>Programme deletion</h2>
---	-----------------------------



This menu is designed to delete programmes already entered into the controller's memory.

1		<p>Press the Menu button, then use the Up or Down buttons to display the Prog menu.</p>	
2		<p>Press the OK button- deL appears on the screen.</p>	
3		<p>Pressing the OK button again will display the number of the first program in the controller's memory.</p> <p>Note: If no programme has been written in the controller's memory, a message will be displayed:</p>	



			
4		<p>Use the Up or Down buttons to select the programme to be deleted.</p> <p>Note: Seconds after changing the program number, programme details appear on the screen.</p>	
5		<p>The upper part of the screen displays days when the programme will be executed, four large digits in the central part of the screen indicate the time when the command will be executed, two small digits in the central part of the screen indicate the time interval when the command will be executed. The On or Off symbol in the lower part of the screen indicates whether the command will switch the relay on or off.</p> <p>Pressing and holding the OK button starts the procedure for deleting the programme.</p>	
6		<p>The del letter with the number of the program to be deleted will blink first. Continue to hold down the OK button until the done message is displayed.</p>	
7		<p>After deleting the program, the number of the next program to be deleted is displayed. You can then continue with the deletion of the next program step (as described in points 4 to 6, or press the Menu button and exit the deletion mode.</p>	

Time periods



Time periods are periods set in an annual cycle, extending between a preset start date and end date. Such an interval, substituted into the clock's operating programme, ensures that such a programme will only be executed inside the set period and ignored outside it.



	Seven periods are defined in the PCZ-528 clock. By default, each of them covers an entire year (from 1 January to 31 December). The user can change the date range assigned to each period, but cannot remove it completely.	
---	--	---











A time period is defined as the period between the start date (month and day of the month), and the end date (month and day of the month), including the start and end date.

	<p>Example:</p> <p>Three working periods are introduced:</p> <p style="padding-left: 40px;">Period 1) 01 January - 31 December,</p> <p style="padding-left: 40px;">Period 2) 15 March - 15 September.</p> <p style="padding-left: 40px;">Period 3) 16 September - 14 March</p> <p>Programmes assigned Period 1 will run throughout the year. Programmes assigned Period 2 will run from 15 March to 15 September (inclusive), Programmes assigned Period 3 will run from 16 September to 14 March (inclusive).</p>	
---	---	---

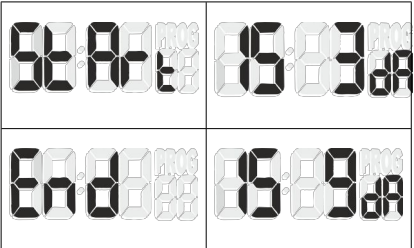
The interval handling menu includes two items:

No	Menu	Function	Website
1		Editing the period	Page 41
2		Resetting the selected period to default values	Page 44

	Editing the time period	
1		<p>Press the Menu button, then use the Up or Down buttons to display the Period menu.</p>
		

2		<p>Press the OK button - the Edit message will appear on the screen.</p>	
3		<p>By pressing the OK button again, the number of the first edited period will be displayed.</p>	
4		<p>Use the Up or Down buttons to select the time interval to edit and confirm the selection by pressing the OK button.</p> <p>Note: Seconds after the period number is displayed, screens with period details - start date and end date - will appear on the display cyclically.</p> <div data-bbox="571 1037 1098 1507" style="border: 1px solid black; padding: 5px;"> <p>Example: Displaying the details of an example work period from 15 March to 15 September.</p>  </div>	
5		<p>A start message informs you that you will be editing the start of the time interval in the next step. Press the OK button to proceed to editing.</p>	
6		<p>The date is displayed as day - month. The month number is set first. Use the Up or Down keys to set the desired value and confirm by pressing the OK key.</p>	

7		<p>In the next step, use the Up or Down keys to set the day number and confirm your selection by pressing the OK key.</p>	
8		<p>Once the start date has been entered, the end date must be entered. The start of this stage is signalled by the End message. To move on to editing the end date, press the OK button.</p>	
9		<p>The end date is also displayed in day-month format and the month number must first be set. Then confirm your selection by pressing the OK button.</p>	
10		<p>Use the Up or Down keys to enter the desired day number.</p>	
11		<p>After confirming the day (OK button), the controller saves the new settings and exits edit mode.</p>	



Restore the default time period

Each of the seven time intervals defined in the controller defaults to cover the entire year (1 January - 31 December). The PCZ-528 does not allow you to delete a time interval completely, instead you can delete the interval to the default values.

1		<p>Press the Menu button, then use the Up or Down buttons to display the Period menu.</p>	
2		<p>Press the OK button - the Default message will appear on the screen.</p>	
3		<p>By pressing the OK button again, the number of the first period will be displayed.</p>	
4		<p>Use the Up or Down keys to select the time interval to be reset and confirm your selection by pressing the OK key.</p> <p>Note: Seconds after the period number is displayed, screens with period details - start date and end date - will appear on the display cyclically.</p> <div data-bbox="576 1648 651 1722" style="float: left; margin-right: 10px;"> </div> <p>Example: Displaying the details of an example work period from 15 March to 15 September.</p> <div data-bbox="667 1839 1082 1968" style="border: 1px solid black; padding: 5px; margin-top: 10px;"> </div>	



5		The word del with the number of the period to be reset will blink first. Continue pressing the OK button until the done message is displayed.	
7		Once the default time interval has been restored, the message with the time interval number will be displayed again. Using the Up or Down keys, you can now select the next interval to be reset or exit to the previous menu using the Menu button.	









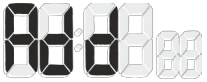
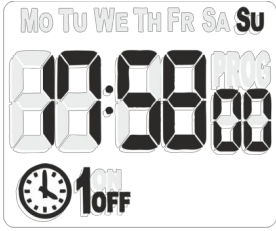

	<h2>Festive days</h2>
--	-----------------------





The PCZ_528 controller allows special days (holidays) to be programmed, during which programmes intended exclusively for holidays will be executed.

	Holidays have priority over other time periods. This means that if a day is listed as a holiday, only programmes intended for holidays can be executed on that day.	
	Programmes to be executed on holidays must have the time interval set to HO (Holiday). 	

The menu for holiday management consists of three items:







No	Menu	Function	Website
1		Adding a new holiday.	Page 44
2		Editing an existing public holiday.	Page 48
3		Removal of existing holiday.	Page 49



 Adding a new public holiday		
1	 <p>Press the Menu button, then use the Up or Down buttons to highlight the Holiday menu.</p>	
2	 <p>Press the OK button - the Add message will appear on the screen.</p>	
3	 <p>Pressing the OK button again will start the procedure for adding another programme.</p> <p>Note: The controller's memory can store up to 30 holidays. When the memory is full, an attempt to add another holiday will be rejected and a memory full message will be displayed.</p> 	
4	 <p>The screen (left) now shows at which position in the holiday table the entry will be stored. The controller automatically substitutes the number of the first free memory cell here.</p> <p>After pressing the OK button, the programme moves on to setting the date.</p>	
5	 <p>The date is displayed as day - month. First set the month number using the Up or Down keys and confirm your choice by pressing OK.</p>	

6		<p>Then use the Up or Down buttons to set the day number of the month.</p>	
7		<p>Pressing OK saves the holiday to the controller's memory. A message appears on the screen with an option to add another holiday. Repeat steps 3-6 to add another holiday, or exit the previous menu by pressing the Menu button.</p>	

	<h3>Festive day edition</h3>
---	------------------------------







This menu is designed for editing holidays already entered in the controller's memory.









1		<p>Press the Menu button, then use the Up or Down buttons to highlight the Holiday menu.</p>	
2		<p>Press the OK button - the Edit message will appear on the screen.</p>	
3		<p>When the OK button is pressed again, the number of the first holiday in the controller's memory is displayed.</p> <p>Note: If no holiday has been stored in the controller's memory, a message will be displayed:</p> <div style="text-align: center; margin-top: 10px;">  </div>	

4		<p>Use the Up or Down keys to select the programme to edit.</p> <p>Note: Seconds after changing the programme number, details of the edited holiday appear on the screen, in date form (day - month).</p> <p>Press the OK button to start editing the holiday. The editing follows the same steps as for adding a holiday.</p>	
---	---	--	---

	<h2>Deleting a public holiday</h2>
---	------------------------------------



This menu is intended for deleting holidays already entered in the controller's memory.

1		<p>Press the Menu button, then use the Up or Down buttons to highlight the Holiday menu.</p>	
2		<p>Press the OK button - the deL message appears on the screen.</p>	
3		<p>When the OK button is pressed again, the number of the first holiday in the controller's memory is displayed.</p> <p>Note: If no holiday has been stored in the controller's memory, a message will be displayed:</p> 	

4		<p>Use the Up or Down keys to select the programme to be deleted.</p> <p>Note: Seconds after changing the programme number, programme details (day - month) appear on the screen.</p>	
5		<p>Pressing and holding the OK button starts the procedure for deleting the holiday.</p>	
6		<p>The word del with the number of the holiday to be deleted will blink first. Continue pressing the OK button until the done message appears.</p>	
7		<p>After deleting the programme, the number of the next programme to be deleted is displayed. You can then continue with the deletion of the next programme steps (as indicated in points 4- 6, or press the Menu button and exit the programme deletion mode.</p>	

	<h2>Location</h2>
---	-------------------

The location menu is designed to set the geographical location in which the clock operates.









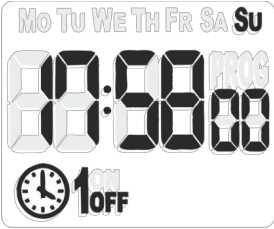

	<p>The correct location setting is essential for the correct operation of the astronomical functions.</p>	
---	---	---







The geographical location can be set in the clock in two ways:



1. By selecting a locality based on a predefined table of locations.
2. By directly setting geographical coordinates (longitude, latitude and time zone).

Location on the basis of the table of localities

The procedure for setting up a location based on a predefined list of localities is shown in the following table.





1		<p>Press the Menu button, then use the Up or Down buttons to display the Locate menu.</p>	
2		<p>After selecting (OK button) the Locate menu, the current location setting will be displayed on the screen. In this window, the screen with the setting mode (User or List) and the details of the setting will cycle through.</p> <p>The example on the right sets the localization based on the list, where the location Pol (Poland) and the city code 41 (Łódź) are set.</p> <p>To go on to edit the parameter, press the OK button again.</p>	 
3		<p>Use the Up or Down buttons to select a location using the list (List) and confirm the selection by pressing the OK button.</p>	
4		<p>When the button is pressed, the current location will be displayed, consisting of two items:</p> <ol style="list-style-type: none"> 1) Four larger digits - the symbol of the country taken out 2) The two smaller digits - the country's city code. <p>A flashing country symbol indicates the possibility of changing the country.</p>	
5		<p>Using the Up or Down keys, select the relevant country (list below)</p>	













6		<p>And then confirm your selection by pressing the OK button - the programme will then move on to selecting the location within the current country.</p>	
7		<p>Use the Up or Down keys to select the correct city code.</p>	
8		<p>And confirm the setting by pressing the OK button.</p>	













	<p>A list with codes of predefined localities is included in the appendix at the end of the instruction. A table with the locations of Polish localities is provided on page 117.</p>	
---	---	---

Location based on geographical coordinates

The procedure for setting the location by directly entering the geographical coordinates and is shown in the diagram below.

1		<p>Press the Menu button, then use the Up or Down buttons to display the Locate menu.</p>	
2		<p>After selecting (OK button) the Locate menu, the current location setting will be displayed on the screen. In this view, the screen with the setting mode (User or List) and details of the setting will cycle through.</p> <p>Example on the right: setting up a location based on a list with location Pol (Poland) and city code 41 (Łódź).</p>	

		To go on to edit the parameter, press the OK button again.	
3		Select the correct mode using the Up or Down keys and confirm your choice by pressing the OK key.	
4		Once confirmed (OK button), the programme moves on to editing the longitude (degrees).	
5		Use the + or - buttons to set the desired number of steps. Note: The 'u' in the first position indicates west longitude, the 'E' indicates east longitude.	
6		The number of steps is confirmed with the OK and we proceed to edit the number of minutes.	
7		Use the + or - buttons to set the desired number of minutes.	
8		The number of minutes is confirmed with the OK button and we move on to editing the latitude.	

9		<p>Use the + or - buttons to set the desired number of steps.</p> <p>Note: The 'n' symbol in the first position indicates north latitude,</p>	
9		<p>The number of steps is confirmed with the OK and we proceed to edit the number of minutes.</p>	
10		<p>Use the + or - buttons to set the desired number of minutes.</p>	
11		<p>Confirm the number of minutes by pressing OK and move on to editing the time zone.</p>	
12		<p>Use the + or - buttons to set the desired time zone.</p> <p>Note: Larger digits indicate the number of hours, smaller ones the number of minutes. A single press of the button moves the time zone by 30min.</p>	
13		<p>Confirm the setting by pressing the OK button.</p>	



Operating mode selection

The **Mode** menu allows selection of whether the controller operates in automatic mode (**Auto**) activating and de-activating the relay according to a preset operating schedule, or in manual mode (**Hand**) continuously maintaining a user-enforced relay state.

1		<p>Press the Menu button, then use the Up or Down buttons to select the Mode menu.</p>	
2		<p>After pressing the OK button, the currently set operating mode will be displayed. Press the OK button again to go to edit the operating mode.</p>	
3		<p>Using the Up or Down keys set the desired operating mode.</p>	
4		<p>And confirm the selection by pressing the OK button. The parameter is saved and the Mode menu is displayed.</p>	

System settings

The **Syst** menu provides access to the advanced settings of the PCZ-528 clock and consists of seven items:





No	Menu	Function	Website
1		Securing access to the controller.	Page 56
2		Management of automatic time change.	Page 57

3		Display brightness level.	Page 58
4		Display contrast.	Page 60
5		Calibration of timekeeping.	Page 60
6		Limiting maximum working hours.	Page 60
7		Cleaning the settings.	Page 60

	PIN security
--	---------------------



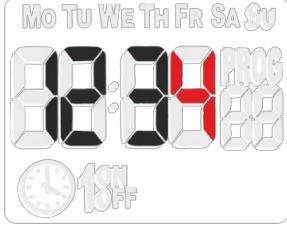

The PIN number enables you to secure access to the PCZ-528 controller's configuration. The PIN security set applies both to local settings and is required when connecting the timer to the PCZ Configurator application.





	Setting the PIN number to 0000 means that the controller's security is deactivated.	
1	<p>Press the Menu button, then use the Up or Down buttons to highlight the Syst.</p>	
2	<p>Press the OK button - the PIN menu will appear on the screen.</p>	
3	<p>After pressing the OK button, a screen for entering a new PIN number is displayed.</p>	

4		<p>Set the first digit of the PIN number using the Up or Down keys. Confirm your choice of digit by pressing the OK button.</p>	
5		<p>The remaining digits of the PIN number should be set in the same way.</p>	
6		<p>Once the last digit is confirmed, the PIN number is set.</p>	

	<h2>Automatic time change</h2>
---	--------------------------------

Activating the automatic time change option allows the time to be automatically updated during the transition between summer and winter time.

1		<p>Using the Up or Down keys display the DST menu.</p>	
2		<p>After pressing the OK button, the current setting value is displayed.</p> <p>The On value means that the controller will automatically correct the time as soon as it detects a change from summer to winter time (and vice versa).</p> <p>The Off value means that the controller will not move the time automatically</p>	

3		Use the Up or Down keys to select the correct parameter value.	
4		And confirm your selection by pressing the OK button.	



	<h3>Screen backlighting</h3>
---	------------------------------

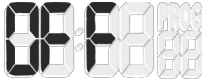
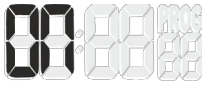







The screen backlight options allow you to set the brightness level of the display and consist of two parameters:

No.	Menu	Function	Description
1		Light Off	Brightness of the display in the clock's normal operating state. The brightness level can be set here in the range 0 - 50% of the macro value.
2		Light On	Brightness of the display in the active state. Switching to the active state takes place when any button on the clock facade is pressed. The active state is maintained for 1 minute after the button is pressed. The brightness level in the active state can be adjusted from 0 to 100% of the maximum value.



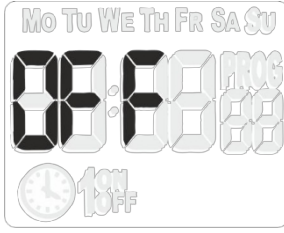

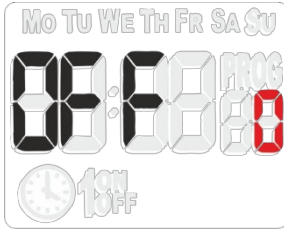
The backlighting corresponding to the adjusted brightness level can be observed when changing the settings.





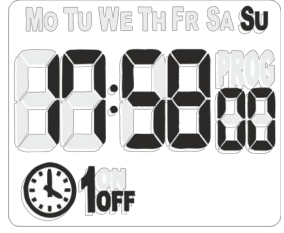

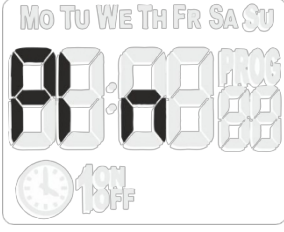

Backlighting in idle state

1		Press the Menu button, then use the Up or Down buttons to highlight the Syst.	
---	---	---	---

2		<p>Press the OK button - the PIN menu will appear on the screen.</p>	
3		<p>Using the Up or Down keys select the Light menu.</p>	
4		<p>Confirm your selection by pressing the OK, the Off menu appears.</p>	
5		<p>After pressing the OK button, the programme goes on to edit the brightness level in idle mode</p>	
6		<p>Use the Up or Down buttons to set the desired brightness level and confirm by pressing the OK button.</p>	

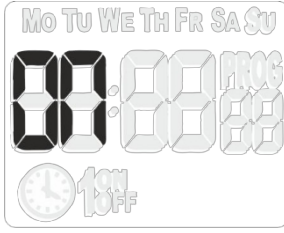
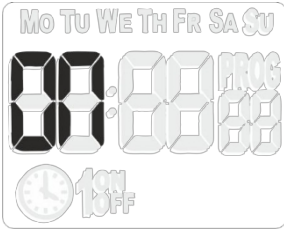

Backlighting in active state







1		<p>Press the Menu button, then use the Up or Down buttons to highlight the Syst.</p>	
2		<p>Press the OK button - the PIN menu will appear on the screen.</p>	

3		Using the Up or Down keys select the Light menu.	
4		Confirm your selection by pressing the OK , the Off menu appears.	
5		Select the On menu using the Up or Down keys and confirm your choice by pressing the OK key.	
5		After pressing the OK button, the programme goes on to edit the brightness level in active mode	
6		Use the Up or Down buttons to set the desired brightness level and confirm by pressing the OK button.	

	Display contrast
---	-------------------------

Changing the contrast of the display. Adjustment range -3 (lowest contrast) ... 3 (highest contrast). Below is an example of reducing the contrast from level 0 to level -3. The changes are immediately visible on the illuminated characters.







1		Using the Up or Down keys display the LCD menu.	
---	---	--	---





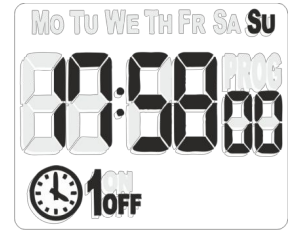



2		<p>After pressing the OK button, the current value of the parameter is displayed.</p>	
3		<p>Use the Up or Down keys to set the desired value.</p>	
4		<p>And confirm the change by pressing the OK button</p>	



Clock calibration



In the event that the clock begins to rush or run late (which is possible due to the ageing of the quartz) then the user can make an appropriate adjustment calculated as the number of seconds per month. The re- gulation range is +/- 300 seconds per month.

	<p>Example: If the clock rushes by four seconds per month then the CAL parameter should be set to -4.</p>		
1		<p>Press the Menu button, then use the Up or Down buttons to highlight the Syst.</p>	
2		<p>Press the OK button - the PIN menu will appear on the screen.</p>	

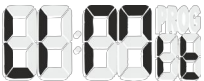

3		Using the Up or Down keys select the CAL menu.	
4		After pressing the OK button, the current value of the parameter will be displayed.	
5		Use the Up or Down buttons to set the new parameter value.	
6		And confirm the change by pressing the OK button	



	<h2>Limitation of working hours</h2>
---	--------------------------------------

The time-limit function allows the maximum total switch-on time of the receiver controlled by the PCZ-528 timer to be set.









	<p>Example: The PCZ-528 timer controls a machine that requires servicing and maintenance every 2000 hours. Therefore, after the set time has elapsed, for the safety of the controlled device, the controller will block the possibility of switching the output on until the service work is carried out and the operating time counter is reset.</p>	
---	---	---

The operating time limitation can be set in 1 hour steps between 1 and 99,999 hours. Setting a value of 0 hours disables the operating time limitation function.

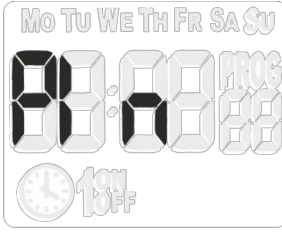
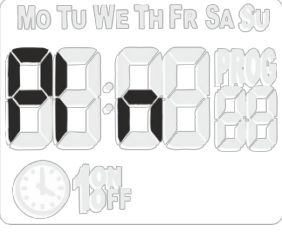
	<p>The runtime limitation counter takes effect when the Limit parameter is set to a non-zero value. The currently counted limit time can be cleared via the menu Syst → Clear → Limit.</p> <p>The remaining time until the limitation is triggered can be observed in the Limit indicator available in the working time statistics menu (p.25).</p>	
---	--	---

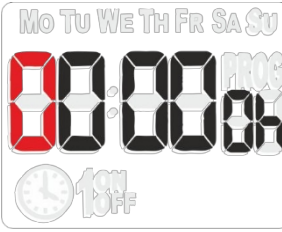
	Reaching the limitation time and locking the controller is signalled by alternate blinking of the 1 and OFF symbols at the bottom of the display.	
---	---	---

Setting the operating time limitation

1		Press the Menu button, then use the Up or Down buttons to highlight the Syst.	
2		Press the OK button - the PIN menu will appear on the screen.	
3		Using the Up or Down keys select the Limit menu.	
4		After pressing the OK button, the current value of the parameter is displayed.	
5		Use the Up or Down keys to set the new value of the digit to be edited. Pressing OK confirms the value of the current digit and moves the edit to the next position.	
6		Pressing the OK button after setting the last digit validates and activates the limit value.	







Cleaning the settings

The settings reset menu is designed to invoke commands to reset the operating time counter, the operating time limit counter and to reset the controller settings to default values. The menu consists of three items:











No	Menu	Function	Description
1		Clear Hist	Resetting of all operating time counters (except the Limit counter).
2		Clear Limit	Resetting the working time limit counter.
3		Clear All	Resetting the controller to factory settings.





Resetting working time statistics

1		Press the Menu button, then use the Up or Down buttons to highlight the Syst.	
2		Press the OK button - the PIN menu will appear on the screen.	
3		Using the Up or Down keys select the Clear menu.	
4		Confirm your selection by pressing the OK , the HIST menu is then displayed.	









5		<p>Press the OK button, after which the text Erease is displayed.</p>	
6		<p>Press and hold the OK button until the done message is displayed.</p>	



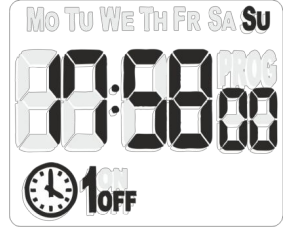

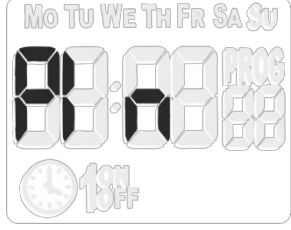

Resetting the operating time limit

1		<p>Press the Menu button, then use the Up or Down buttons to highlight the Syst.</p>	
2		<p>Press the OK button - the PIN menu will appear on the screen.</p>	
3		<p>Using the Up or Down keys select the Clear menu.</p>	
4		<p>Confirm your selection by pressing the OK, the HIST menu is then displayed.</p>	
5		<p>Use the Up or Down keys to select the menu Limit.</p>	

5		Press the OK button, after which the text Erease is displayed.	
6		Press and hold the OK button until the done message is displayed.	

Deleting all settings

	<p>The Clear All command deletes all settings and operating programmes of the controller. Only the current clock display (date and time) is retained.</p>		
1		Press the Menu button, then use the Up or Down buttons to highlight the Syst.	
2		Press the OK button - the PIN menu will appear on the screen.	
3		Using the Up or Down keys select the Clear menu.	
4		Confirm your selection by pressing the OK , the HIST menu is then displayed.	



5		Use the Up or Down keys to select the menu All .	
5		Press the OK button, after which the text Erease is displayed.	
6		Press and hold the OK button until the done message is displayed.	

Working time history

The PCZ-528 timer records the relay switching time by current day, month, and months of the last year. For more on the **Hist** menu structure, see page 25.

Device information

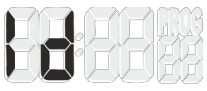
The Info menu provides basic information about the version and current status of the controller. It consists of four items:

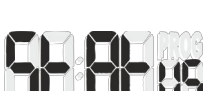
No	Menu	Function	Description
1		Id	Device type identifier.
2		Soft	Controller software version.
3		Batt	Current battery level.
4		Status	Information about the current status of the device. A good message indicates normal operation, Err messages indicate faults (more on page 20)

Part 6 Mobile application





The PCZ-528 controller can also be programmed remotely using a smartphone and the **PCZ Configurator** mobile app. The connection uses very close communication (NFC), the same communication that is used for, among other things, contactless payments.

The smartphone used for programming must meet the following conditions:

- working under the control of the Android operating system,
- access to Google services,
- NFC communication supported.

The control app is available free of charge in the shop:



	<p>The NFC connection uses very short-range communication, which means that the phone must be placed directly on the front of the programmable controller.</p>	
	<p>Due to the wide variety of types and sizes of modern phones, it can sometimes be necessary to determine the correct way to place the phone on the controller. If you have problems establishing a connection, it is recommended that you slowly move the phone over the front of the clock until the connection is established. Establishing a connection is (usually) signalled by the phone vibrating and the PCZ Configurator application starting, or by a prompt to start the PCZ Configurator application.</p>	

The application allows:

- Creation and editing of work programmes.
- Management of the list of public holidays.
- Setting operating periods.
- Selection of the controller's location, whether based on a list of localities, an indication of the location on a map or a direct location provided by the GPS on the phone.
- Access to clock settings.
- Review of working time statistics.

The configuration thus prepared can be:

- Written and read into the controller.
- Recorded as a data file.
- Shared configuration with other users via the sharing mechanisms available in Android.

As each PCZ controller has its own unique ID number, the configuration read from the controller is automatically stored in the phone's memory. This function makes it possible to keep a history of the controller's configuration changes and easily restore previous settings.

Home screen

The home screen is displayed when the application is launched manually

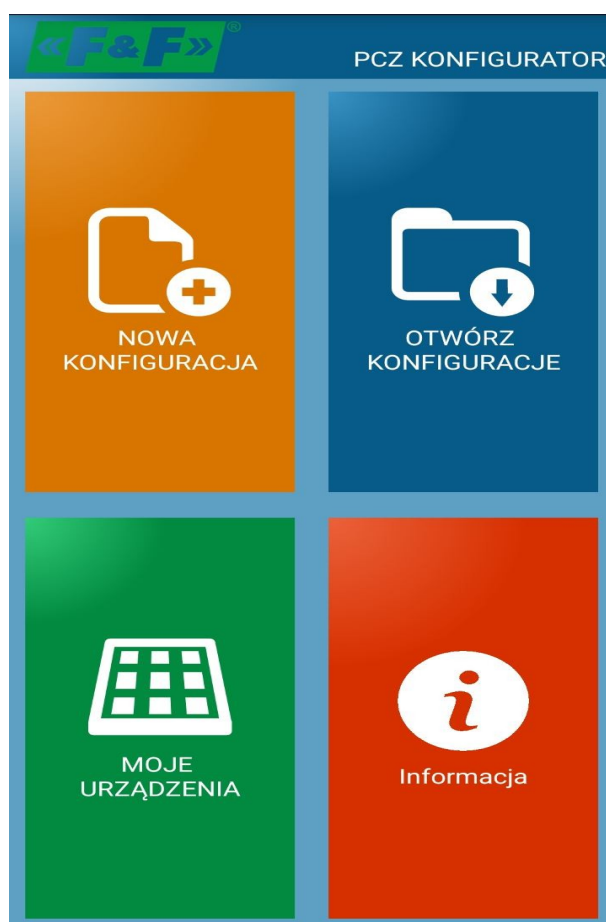

It consists of four tiles, which can be used to select the direction of the application:





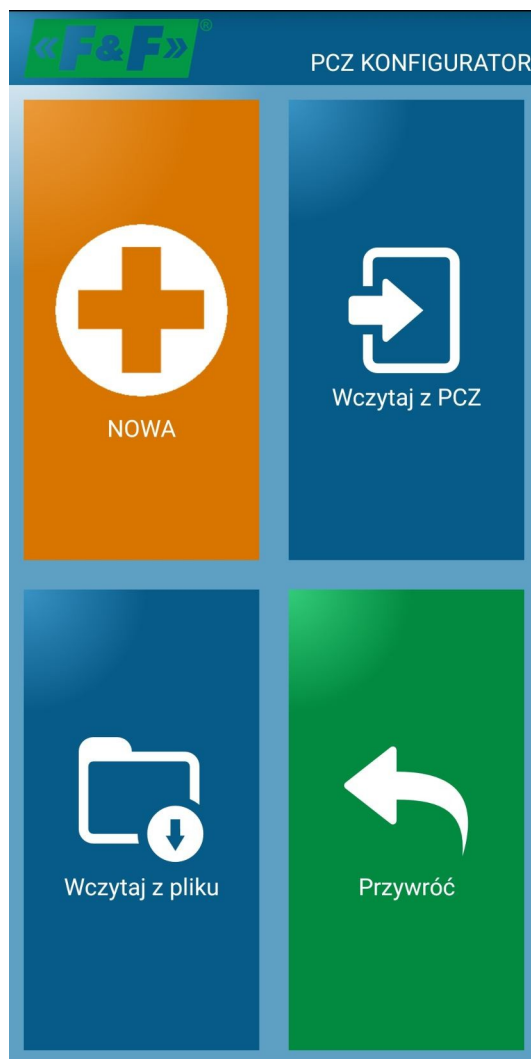

New configuration

The **New Configuration** button opens a view to create a new configuration for the clock operation.

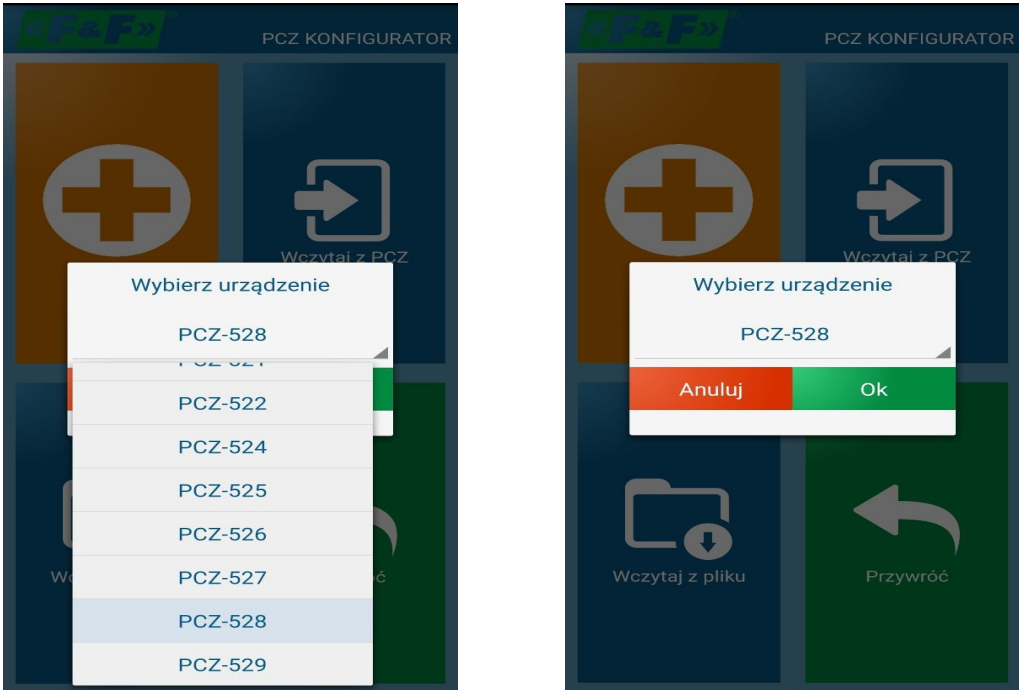

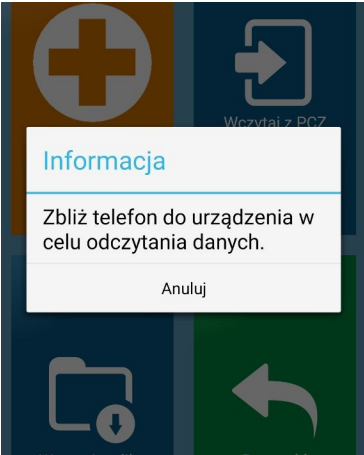
A new configuration can be created in one of the four ways described below. Once an existing configuration has been created or opened, the device view screen (page 75) will be displayed to allow further processing of the configuration (editing, writing to a clock or to a file).

	<p>Press the New button to create an empty configuration for the selected clock type. To do this, expand the displayed list of clock types and select the correct one.</p> 
	<p>Reading the configuration from the PCZ clock. After selecting this option, follow the on-screen instructions: bring the phone close to the front of the clock and wait for the settings to finish downloading.</p> 
	<p>The Load from file button provides a list of configurations saved by the user. The configurations are grouped into folders based on device type. After selecting a device folder, a list of saved configurations is displayed.</p>

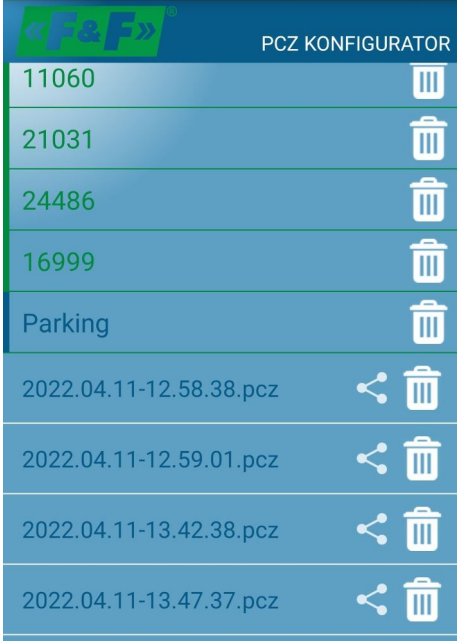
	 -> 
	<p>The Restore button makes the automatically created configuration files available. The PCZ Configurator application automatically creates such a file when a new configuration is saved to the clock. The files are organised here as folders referring to serial numbers (or user-assigned identifiers), and the file name is linked to the date the configuration was saved to the PCZ clock.</p>  -> 



Open configuration

The **Open Configuration** button provides a list of configurations saved by the user. The configurations are grouped into folders based on device type. When a device folder is selected, the list of saved configurations will be displayed.



->



When a configuration file is selected, the device view screen (p. 75) is displayed to allow further processing of the configuration (editing, writing to a clock or to a file).















My devices

The **My Devices** button provides access to the automatically created configuration files. The PCZ Configuration application automatically creates such a file when a new configuration is written to the clock. The files are organised here as folders corresponding to the serial numbers (or user-assigned identifiers), and the file name is linked to the date the configuration was saved to the PCZ clock.

«F&F» [®] PCZ KONFIGURATOR	
54905	
520096364	
1	
11060	
21031	
24486	
16999	
Parking	

->

«F&F» [®] PCZ KONFIGURATOR	
11060	
21031	
24486	
16999	
Parking	
2022.04.11-12.58.38.pcz	 
2022.04.11-12.59.01.pcz	 
2022.04.11-13.42.38.pcz	 
2022.04.11-13.47.37.pcz	 

When a configuration file is selected, the device view screen (p. 75) is displayed to allow further processing of the configuration (editing, writing to a clock or to a file).

	<p>Information</p>
---	---------------------------

The Information button provides brief information on how to use the PCZ Configurator application.

Device screen

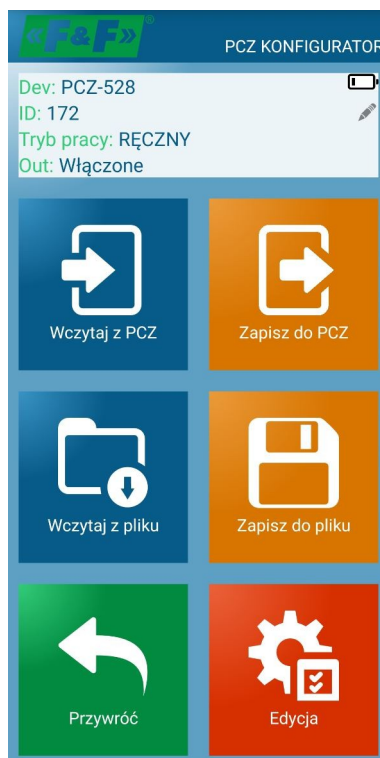

The device screen will be displayed when:

- create an empty configuration for the selected clock type,
- reading the clock configuration from a file,
- reading the configuration from the PCZ clock.

The screen is organised into two blocks. The upper one displays information about the device for which the configuration is being created, while below it there are buttons to trigger further actions related to the clock configuration.

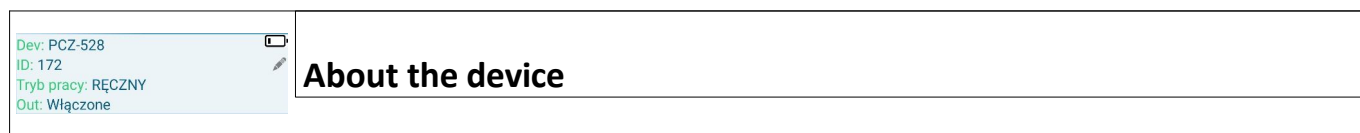

Dev	Clock type identifier
ID	Serial number of the clock. The pencil symbol to the right allows you to enter a custom name for the device. Once entered, this name will appear in the clock ID field, and in the list of automatically created backups.
Mode of operation	Indicates the current clock mode setting (automatic or manual).
Out	Last relay output status read.

For the PCZ-528 timer, an icon is displayed in the top right-hand corner indicating the level of charge of the battery supporting timekeeping in the timer in the absence of power supply.



Read from PCZ

Reading the configuration from the PCZ clock. After selecting this option, follow the on-screen instructions: bring the phone close to the front of the clock and wait for the settings to finish downloading.

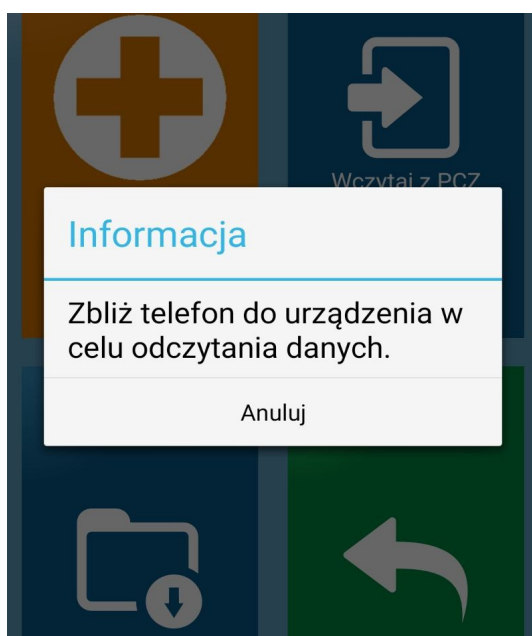

->

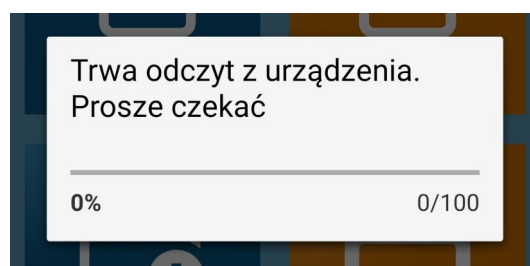



Subscribe to the MS

Save the current configuration to the clock. Bring the phone close to the front of the clock and follow the directions displayed on the phone screen. Do not move the phone away from the clock

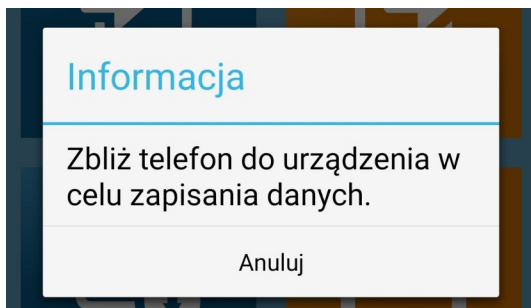

->

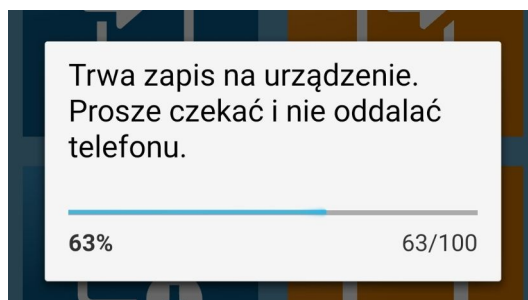

Successful completion of the recording is signalled by the following message:

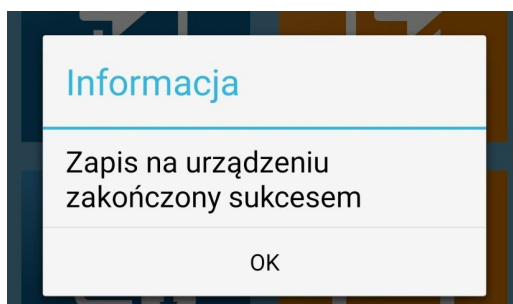

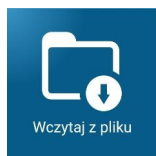

Read from file

The **Load from file** button provides a list of configurations saved by the user and compatible with the currently selected clock type.



->

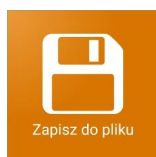
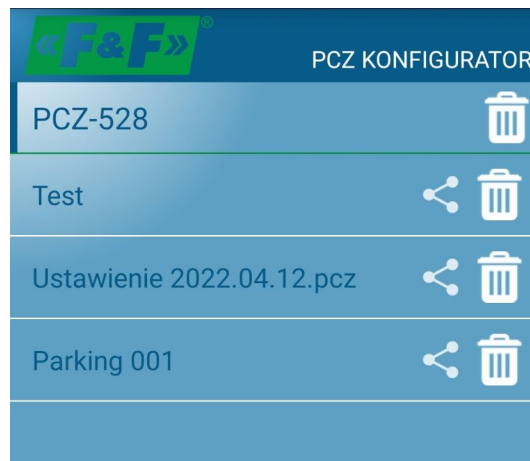

Save to file

The **Save to file** option allows the current configuration to be saved to a file stored on the mobile device. Enter a name for the file in the edit field displayed and then press the **Save** button.

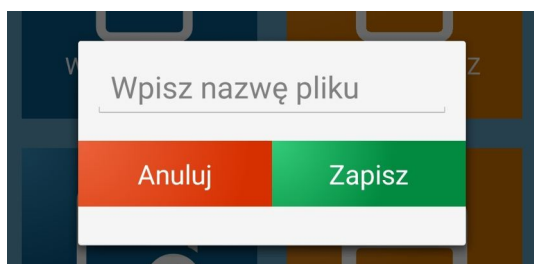



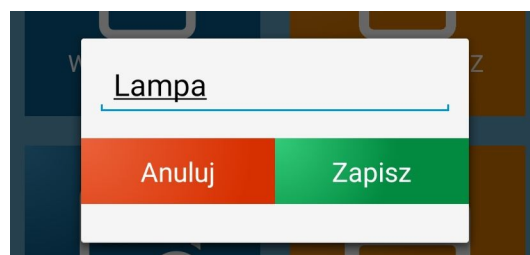



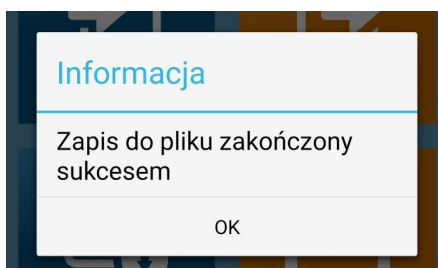



->



The correct saving of data to the file is confirmed by a message:



	<p>The file is saved in the folder associated with the device type and will be automatically available if you try to read the file.</p> 	
	<p>Clock configuration files are stored in a file space reserved for the PCZ Configurator application and as such may be inaccessible directly to e.g. file managers. File sharing is possible via the share icon visible to the right of the file name.</p>  <p>Selecting the share icon launches the phone's built-in mechanism for downloading and sharing files via file managers, email, network communicators, data clouds, etc.</p>	
	<p>Unnecessary configuration files or folders can be deleted by pressing the trash button to the right of the file or folder name.</p>  <p>The deletion of a file or folder must be confirmed each time by pressing the Delete button in the dialog box that appears</p> <div style="display: flex; align-items: center; justify-content: center;"> <div data-bbox="268 1581 724 1805" style="border: 1px solid black; padding: 5px; margin-right: 20px;"> <p style="text-align: center; color: blue;">Czy napewno chcesz usunąć konfiguracje?</p> <div style="display: flex; justify-content: space-around;"> Anuluj Usuń </div> </div> -> <div data-bbox="863 1581 1319 1794" style="border: 1px solid black; padding: 5px; margin-left: 20px;"> <p style="text-align: center; color: blue;">Czy napewno chcesz usunąć cały folder ustawień?</p> <div style="display: flex; justify-content: space-around;"> Anuluj Usuń </div> </div> </div>	
	<p>Deleting a configuration file or folder is an irreversible operation. Care must therefore be taken, especially when deleting entire configuration folders.</p>	



The **Restore** button makes available automatically created configuration files intended for clocks of the currently selected type. The **PCZ Configurator** application automatically creates such a file when a new configuration is saved to the clock. The files are organised here as folders corresponding to the serial numbers (or user-assigned identifiers), and the file name is linked to the date the configuration was saved to the PCZ clock.

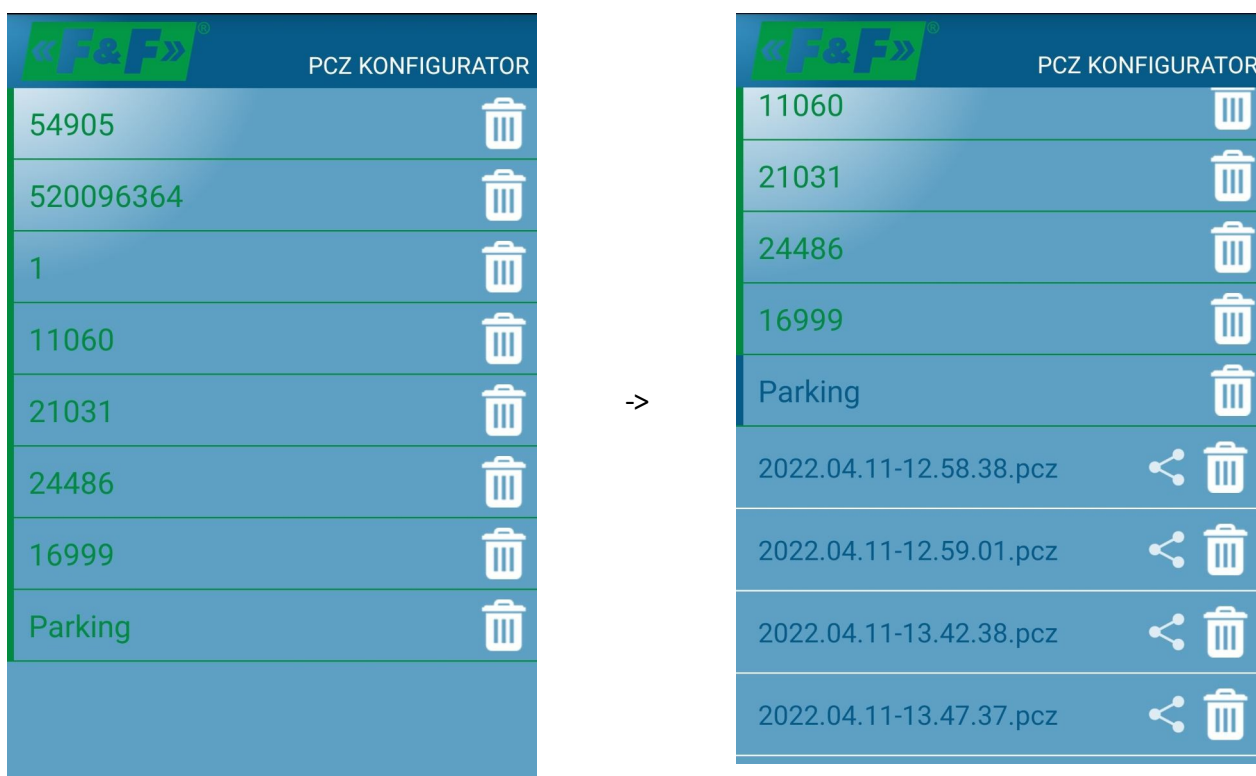



The **Edit** button launches the programme editor (p. Error: Reference source not found), which enables the preparation and editing of the work programme designed for the selected clock type. The appearance and functionality of the settings editor depend on the type of clock.

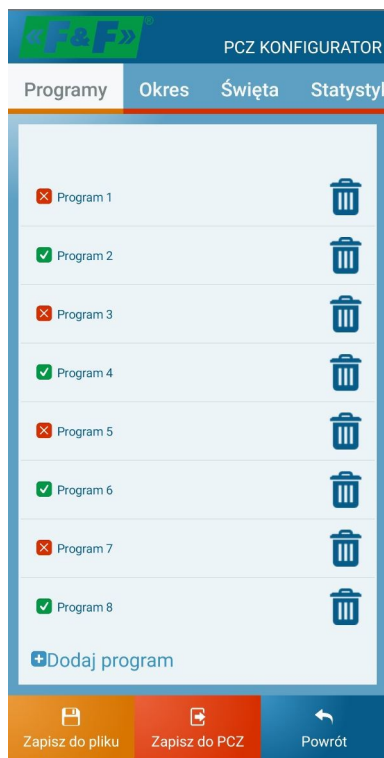

The editor makes it possible to prepare or edit the work programme carried out by the PCZ timer.



The programme settings are organised in tabs selected at the top of the screen (Programmes, Period, Holidays, ...). The central part of the screen contains the detailed settings contained in the following tabs.

	The structure and content of the tabs depends on the selected clock type. The following instruction presents the configuration of the PCZ-528 clock only.	
---	---	---

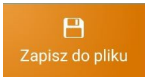
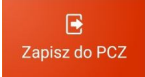
There are three function buttons at the bottom of the screen:

	Saves the currently edited configuration to a file
	Saves the current configuration to the PCZ clock
	Return to device screen (page 75)

<h1>Programy</h1>	Programmes
-------------------	-------------------

The **Programs** tab allows you to add, edit or delete individual program steps for the timer. A list of entered program steps is displayed in the central part of the screen. The step number is assigned automatically and corresponds to the memory cell number in which the programme will be saved in the PCZ timer memory.

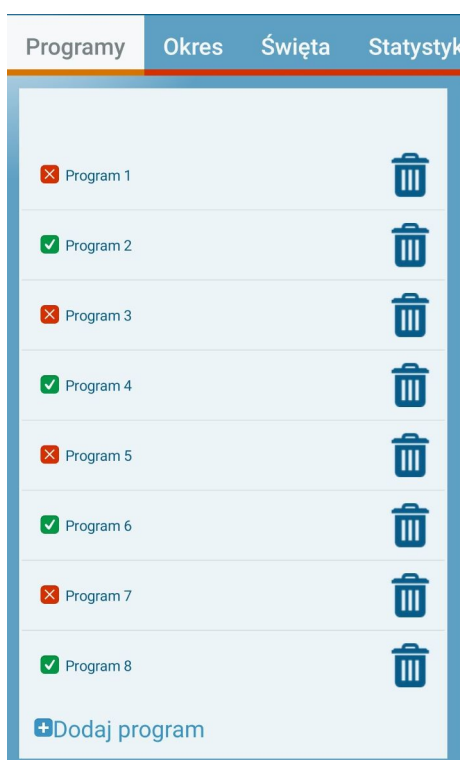



Clicking on the programme name will display a screen with details of the programme step.

	Button to add another empty programme step to the list and display the programme edit- tor.
	Delete the selected programme step.

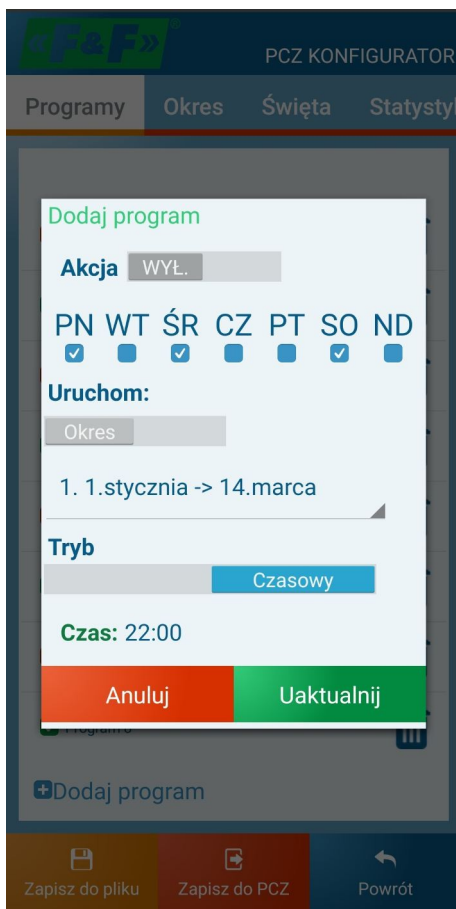
The programme details window is a view that allows you to add or edit an existing programme step.



Within each programme, the user must set:

<p>Akcja</p>	<p>The selected action that the relay will perform at the time set below:</p> <p>Akcja WYŁ. - switching off the relay</p> <p>Akcja WŁ. - switching on the relay</p>	
	<p>Selection of the days of the week on which the entered programme step will be performed.</p> <p>PN WT ŚR CZ PT SO ND</p> <p><input checked="" type="checkbox"/> <input type="checkbox"/> <input checked="" type="checkbox"/> <input type="checkbox"/> <input type="checkbox"/> <input checked="" type="checkbox"/> <input type="checkbox"/></p>	
	<p>The selection of days of the week is ignored if a programme step is set to be executed on public holidays.</p>	

<h2 style="background-color: #e1f5fe; padding: 5px;">Uruchom</h2>	<p>Selection of the time period during which the current step will be executed. Two options are possible here, set by the switch below the Run text.</p> <p>Period - the programme will be executed in the specified date range.</p> <div data-bbox="368 353 762 506" style="border: 1px solid #ccc; padding: 5px; margin-bottom: 10px;"> <p>Uruchom:</p> <p>Okres</p> <p>1. 1.stycznia -> 14.marca</p> </div> <p>The period number (1 to 7) is selected using the drop-down list, while the date range corresponding to each period number is set in the Period tab.</p> <div data-bbox="368 629 624 931" style="border: 1px solid #ccc; padding: 5px; margin-bottom: 10px;"> <p>1. 1.stycznia -> 14.marca</p> <p>2. 15.marca -> 14.czerwca</p> <p>3. 15.czerwca -> 14.września</p> <p>4. 15.września -> 31.grudnia</p> <p>5. 1.stycznia -> 31.grudnia</p> <p>6. 1.stycznia -> 31.grudnia</p> <p>7. 1.stycznia -> 31.grudnia</p> <p>1. 1.stycznia -> 14.marca</p> </div> <p>Holidays - the programme will only be executed on holidays, i.e. those that have been added to the list in the Holidays tab.</p> <div data-bbox="368 1055 762 1207" style="border: 1px solid #ccc; padding: 5px; margin-bottom: 10px;"> <p>Uruchom:</p> <p style="text-align: right; background-color: #00bcd4; color: white; padding: 2px 10px; border-radius: 5px;">Święta</p> </div>
<h2 style="background-color: #e1f5fe; padding: 5px;">Tryb</h2>	<p>The moment when the relay is switched on/off is set in the Mode field. Depending on the settings of the relay located there, it can be set:</p> <p>A timed mode in which switching on/off will take place at a preset hour and minute.</p> <div data-bbox="368 1525 775 1677" style="border: 1px solid #ccc; padding: 5px; margin-bottom: 10px;"> <p>Tryb</p> <p style="text-align: right; background-color: #00bcd4; color: white; padding: 2px 10px; border-radius: 5px;">Czasowy</p> <p>Czas: 22:00</p> </div> <p>To set the start-up time of the programme, click on the time next to the word Time and use the displayed timer to set the desired time and mi- note.</p>

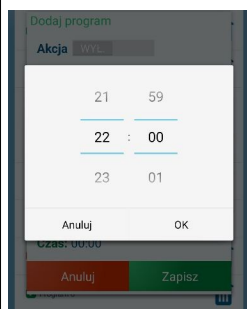

Astronomical mode, in which the moment of switching on/off depends on the astronomical time linked to the position of the sun in relation to the horizon.

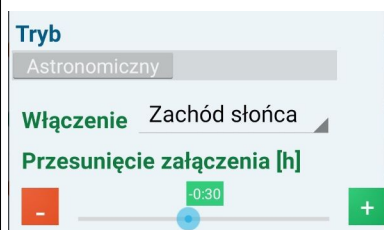

From the drop-down list, you can select one of four predefined points corresponding to sunset, dusk, dawn and sunrise.

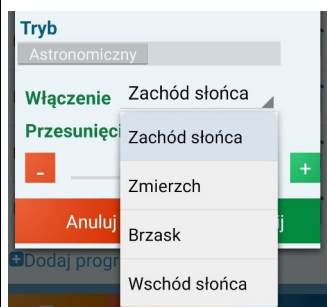

The switching moment can be further adjusted using the switch-on offset slider. A value greater than zero will start the programme **after** the set astronomical point (e.g. **after** sunset). A value less than zero will start the programme **before** the set astronomical point (e.g. **before** sunrise).



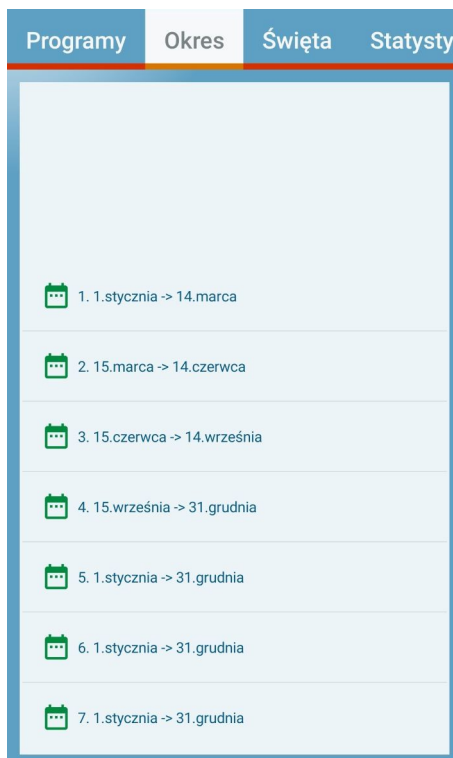

<h1>Okres</h1>	<p>Perio d</p>
----------------	---------------------------

The PCZ-528 timer has seven independent date ranges defined. Each of the programme steps may have one of the intervals selected here, which means that the programme will only be executed in the specified date range (e.g. from 1 January to 14 March).



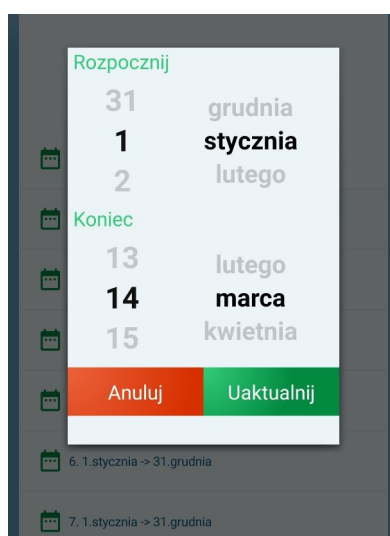

To change the date range, click on one of the entries in the list above and set the start and end dates using the following tools.

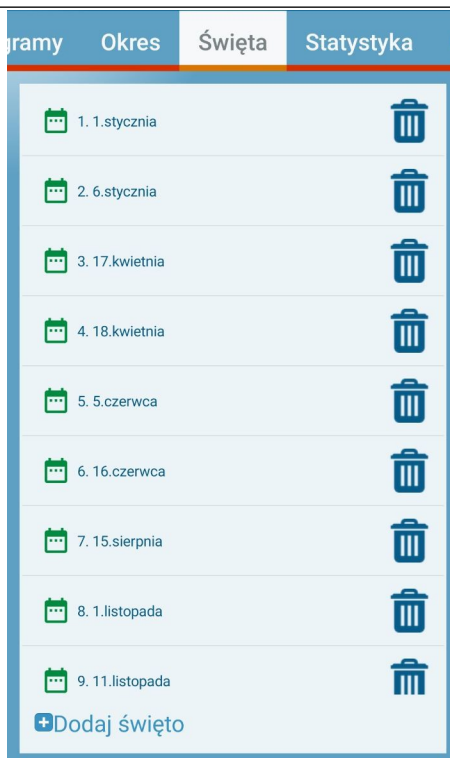

<h1>Święta</h1>	<h2>Holidays</h2>	
	<p>On holidays in the user-defined list, only programs set to run on holidays will be executed. This means that on 3 May, for example, only program steps with the Run field set to Holiday will be executed and all steps set to Period will be ignored.</p>	





	<h3>Adding another holiday to the list of public holidays</h3>
	
	<h3>Removing a selected holiday from the list</h3>

<h1 style="margin: 0;">Statystyka</h1>	<h2 style="margin: 0;">Statistics</h2>
--	--

The operating time statistics show the switching time of the relay broken down by the current day, month and the previous 12 months. The detailed switch-on time can be read by clicking on the bar corresponding to the selected month.

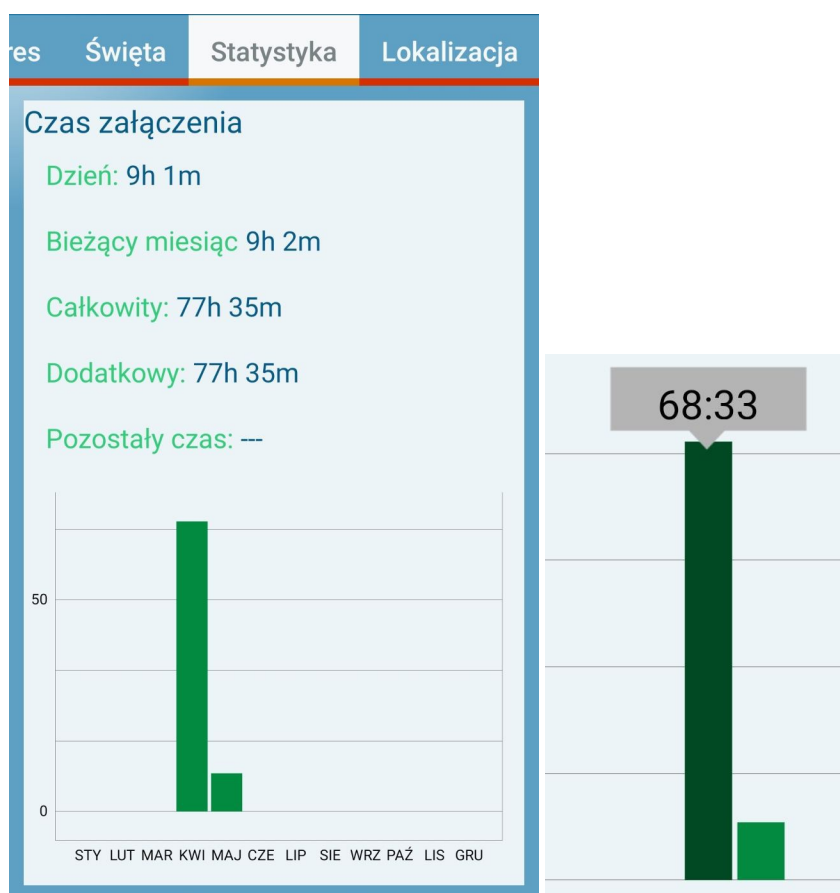

The Remaining time field becomes active when the PCZ-528 timer is set to the operating time limit and indicates the time remaining until the relay is locked.



	<p>The operating time counters are updated every 60 minutes when the relay is switched on and when the timer is de-energised.</p>	
---	---	---

Lokalizacja	Location
--------------------	-----------------

The Location tab is for setting the location where the clock is mounted.

	The correct setting of the clock location is essential for the correct calculation of the sun's position and the operation of the clock's astronomical functions.	
---	---	---

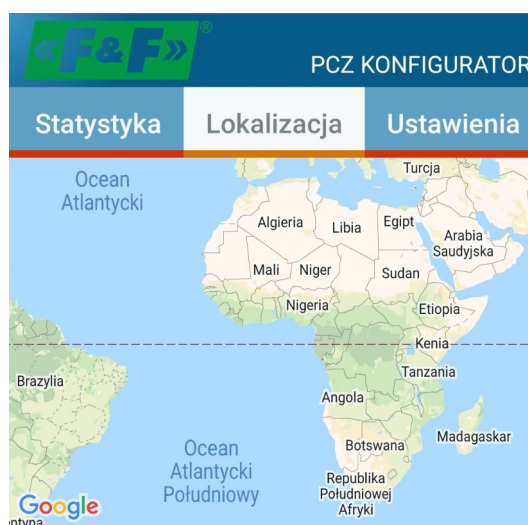

Lokalizacja:

Polska, Lodz | [zmień](#) |

Strefa czasowa: 1.0

The current location is indicated on the screen above. To select a new one, press the **Change**. The new location can be set in two ways:

List - locality based on a list of localities. First select the country from the list shown in the figure below, and then choose the closest of the localities defined there from the expanded list of localities in the given country.







You can also use the search field (next to the pencil symbol) and enter the name of the place you are looking for there.

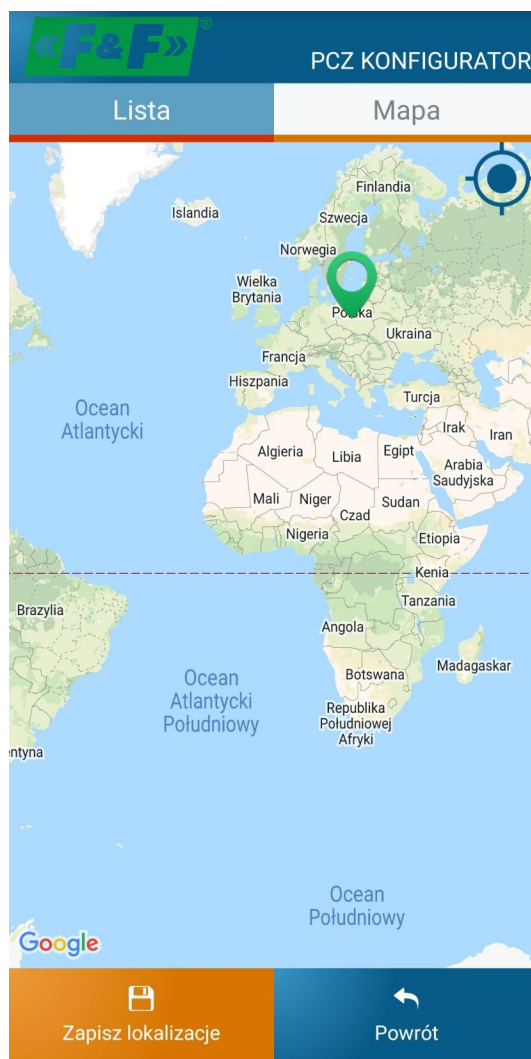

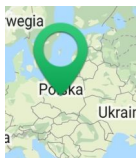
Map - map-based location. In this case, it is possible to indicate directly on the map the location of the clock.



	<p>This symbol indicates the currently selected clock location</p>	
	<p>If you see such an icon in the top right-hand corner of the screen, it means that the application has an exact location read out via the phone's GPS system. Clicking on such an icon will set the selected location according to the GPS readings.</p>	
	<p>Once the new location has been selected, confirm it by pressing the Save Location button.</p>	
		

Ustawienia





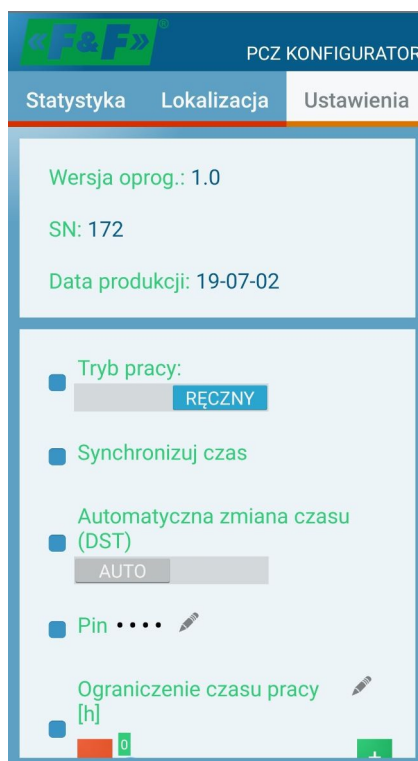

Settings



Advanced clock settings PCZ-528



	<p>Only the settings selected by the user are rewritten to the controller. This is done by ticking the control to the left of the parameter.</p> <ul style="list-style-type: none"> <input type="checkbox"/> - Light inactive. The setting of the selected parameter will not be transferred to the clock. <input checked="" type="checkbox"/> - Control active. The selected setting will be sent to the clock and overwrite the existing setting. 	
--	---	--

Mode of operation	Clock mode selection	
		Manual operation. Push-button relay switching.
		Automatic operation. Relay switching based on a programmed operating schedule.

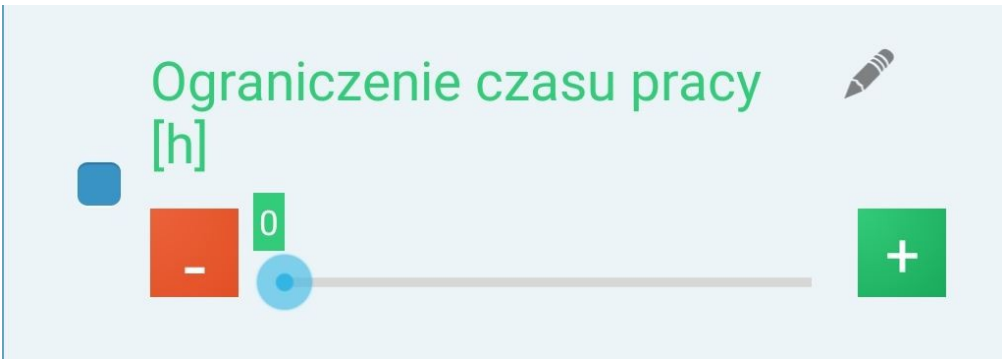
<p>Synchronise time</p>	<p>Transcribing the current time and date from the phone to the PCZ clock.</p> <div data-bbox="467 248 1471 409" style="border: 1px solid #ccc; padding: 10px; background-color: #e6f2ff;">  </div> <div data-bbox="483 432 1455 544" style="border: 1px solid #ccc; padding: 5px;"> <div style="display: flex; align-items: center; justify-content: space-between;"> <div style="border: 1px solid #ccc; padding: 5px; width: 30%;">  </div> <div style="text-align: center; flex-grow: 1;"> <p>Time is set to the nearest whole minute</p> </div> <div style="border: 1px solid #ccc; padding: 5px; width: 30%;">  </div> </div> </div>	
<p>Automatic time change (DST)</p>	<p>Setting that determines whether the clock is automatically corrected when a transition between summer and winter time is detected</p> <div data-bbox="475 757 930 887" style="border: 1px solid #ccc; padding: 10px; background-color: #e6f2ff;"> <p>Automatyczna zmiana czasu (DST)</p> <p><input checked="" type="checkbox"/> AUTO</p> </div>	<p>The clock will advance the time when a time change is detected.</p>
	<div data-bbox="475 931 930 1048" style="border: 1px solid #ccc; padding: 10px; background-color: #e6f2ff;"> <p>Automatyczna zmiana czasu (DST)</p> <p><input checked="" type="checkbox"/> RĘCZNY</p> </div>	<p>Time will remain the same</p>
<p>Pin</p>	<p>Setting a PIN number to secure access to the controller configuration.</p> <div data-bbox="467 1167 1471 1294" style="border: 1px solid #ccc; padding: 10px; background-color: #e6f2ff;"> <p>Pin •••• </p> </div> <p>To enter the PIN number, press the pencil symbol and then enter the 4-character PIN.</p> <div data-bbox="467 1406 976 1787" style="border: 1px solid #ccc; padding: 10px; background-color: #e6f2ff;"> <p>Automatyczna zmiana czasu (DST)</p> <p><input checked="" type="checkbox"/> RĘCZNY</p> <div style="border: 1px solid #ccc; padding: 5px; margin: 5px 0;"> <p>1000</p> </div> <div style="display: flex; justify-content: space-between; margin-top: 5px;"> Anuluj Ok </div> </div> <div data-bbox="483 1809 1455 1951" style="border: 1px solid #ccc; padding: 5px;"> <div style="display: flex; align-items: center; justify-content: space-between;"> <div style="border: 1px solid #ccc; padding: 5px; width: 30%;">  </div> <div style="text-align: center; flex-grow: 1;"> <p>You should protect yourself against the possibility of losing your PIN number. Its absence blocks the possibility of changing the clock settings.</p> </div> <div style="border: 1px solid #ccc; padding: 5px; width: 30%;">  </div> </div> </div>	
<p>Time limitation</p>	<p>Limitation of the relay's total switching time. The limiting time can be</p>	

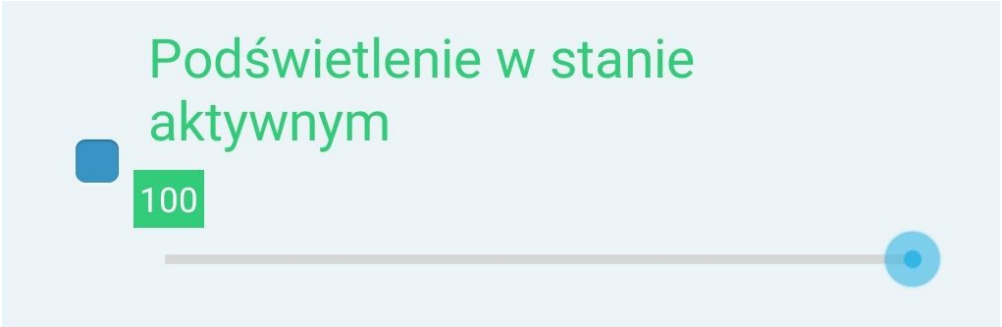
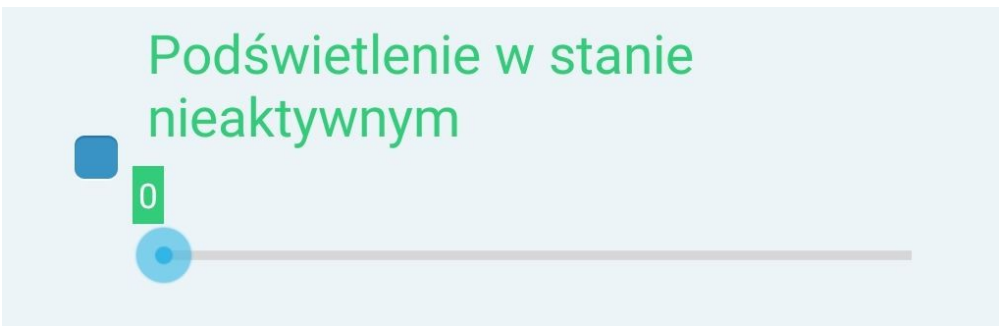

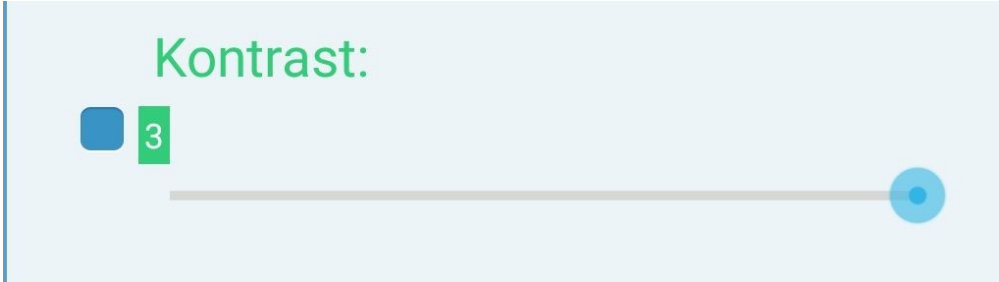
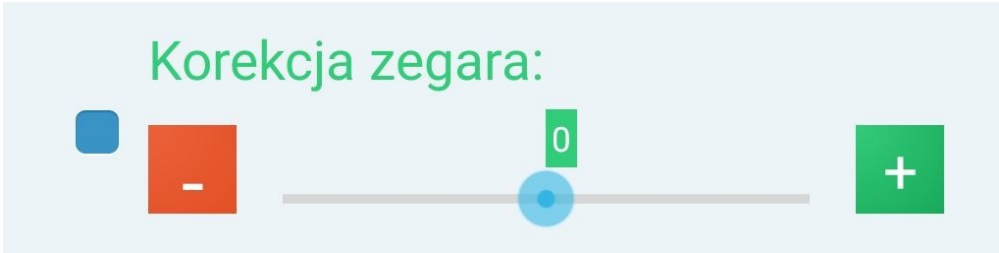
<p>work</p>	<p>set using the slider and the +/- keys. It is also possible to enter a direct average numerical value by pressing the pencil icon.</p>  <div style="border: 1px solid black; padding: 5px; margin-top: 10px;">  Setting the limitation to 0 disables the runtime control function.  </div>
<p>Backlighting in the active state</p>	<p>Brightness of the display during normal clock operation. The brightness level can be set here in the range of 0 - 50% of the maximum value.</p> 
<p>Backlight inactive</p>	<p>Brightness of the display in the active state. The display switches to the active state when any button on the clock facade is pressed. The active state is maintained for 1 minute after the button is pressed. The brightness level in the active state can be adjusted from 0 - 100% of the maximum value.</p> 
<p>Contrast</p>	<p>Changing the contrast of the display. Adjustment range -3 (lowest contrast) ...</p>

	<p>3 (highest contrast). Below is an example of reducing the contrast from level 0 to level -3.</p> 
<p>Clock correction</p>	<p>If the clock starts to go haywire or late (which is possible as a result of quartz ageing) then the user can enter an appropriate adjustment calculated as the number of seconds per month. The adjustment range is +/- 300 seconds per month.</p> 

Part 7 List of defined locations

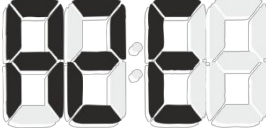
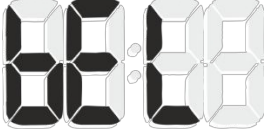
Lp.	Name	Code	LCD	List of localities																																						
1	Albania	ALB		<table border="1"> <tr><td>1</td><td>Berat</td></tr> <tr><td>2</td><td>Durres</td></tr> <tr><td>3</td><td>Elbasan</td></tr> <tr><td>4</td><td>Fier</td></tr> <tr><td>5</td><td>Gjirokaster</td></tr> <tr><td>6</td><td>Kavaje</td></tr> <tr><td>7</td><td>Korce</td></tr> <tr><td>8</td><td>Lac</td></tr> <tr><td>9</td><td>Lushnje</td></tr> <tr><td>10</td><td>Pathos</td></tr> <tr><td>11</td><td>Pogradec</td></tr> <tr><td>12</td><td>Shkoder</td></tr> <tr><td>13</td><td>Tirane</td></tr> <tr><td>14</td><td>Vlore</td></tr> </table>	1	Berat	2	Durres	3	Elbasan	4	Fier	5	Gjirokaster	6	Kavaje	7	Korce	8	Lac	9	Lushnje	10	Pathos	11	Pogradec	12	Shkoder	13	Tirane	14	Vlore										
1	Berat																																									
2	Durres																																									
3	Elbasan																																									
4	Fier																																									
5	Gjirokaster																																									
6	Kavaje																																									
7	Korce																																									
8	Lac																																									
9	Lushnje																																									
10	Pathos																																									
11	Pogradec																																									
12	Shkoder																																									
13	Tirane																																									
14	Vlore																																									
2	Armenia	ARM		<table border="1"> <tr><td>1</td><td>Abovyan</td></tr> <tr><td>2</td><td>Armavir</td></tr> <tr><td>3</td><td>Gavar</td></tr> <tr><td>4</td><td>Gyumri</td></tr> <tr><td>5</td><td>Hrazdan</td></tr> <tr><td>6</td><td>Kapan</td></tr> <tr><td>7</td><td>Vagharshapat</td></tr> <tr><td>8</td><td>Vanadzor</td></tr> <tr><td>9</td><td>Yerevan</td></tr> </table>	1	Abovyan	2	Armavir	3	Gavar	4	Gyumri	5	Hrazdan	6	Kapan	7	Vagharshapat	8	Vanadzor	9	Yerevan																				
1	Abovyan																																									
2	Armavir																																									
3	Gavar																																									
4	Gyumri																																									
5	Hrazdan																																									
6	Kapan																																									
7	Vagharshapat																																									
8	Vanadzor																																									
9	Yerevan																																									
3	Austria	AUT		<table border="1"> <tr><td>1</td><td>Amstetten</td></tr> <tr><td>2</td><td>Baden</td></tr> <tr><td>3</td><td>Bregenz</td></tr> <tr><td>4</td><td>Dornbirn</td></tr> <tr><td>5</td><td>Feldkirch</td></tr> <tr><td>6</td><td>Graz</td></tr> <tr><td>7</td><td>Innsbruck</td></tr> <tr><td>8</td><td>Kapfenberg</td></tr> <tr><td>9</td><td>Klagenfurt</td></tr> <tr><td>10</td><td>Klosterneuburg</td></tr> <tr><td>11</td><td>Krems</td></tr> <tr><td>12</td><td>Leoben</td></tr> <tr><td>13</td><td>Leonding</td></tr> <tr><td>14</td><td>Linz</td></tr> <tr><td>15</td><td>Modling</td></tr> <tr><td>16</td><td>Salzburg</td></tr> <tr><td>17</td><td>Sankt polten</td></tr> <tr><td>18</td><td>Steyr</td></tr> <tr><td>19</td><td>Traun</td></tr> </table>	1	Amstetten	2	Baden	3	Bregenz	4	Dornbirn	5	Feldkirch	6	Graz	7	Innsbruck	8	Kapfenberg	9	Klagenfurt	10	Klosterneuburg	11	Krems	12	Leoben	13	Leonding	14	Linz	15	Modling	16	Salzburg	17	Sankt polten	18	Steyr	19	Traun
1	Amstetten																																									
2	Baden																																									
3	Bregenz																																									
4	Dornbirn																																									
5	Feldkirch																																									
6	Graz																																									
7	Innsbruck																																									
8	Kapfenberg																																									
9	Klagenfurt																																									
10	Klosterneuburg																																									
11	Krems																																									
12	Leoben																																									
13	Leonding																																									
14	Linz																																									
15	Modling																																									
16	Salzburg																																									
17	Sankt polten																																									
18	Steyr																																									
19	Traun																																									

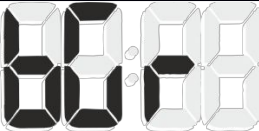
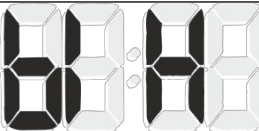
				20 Villach	
				21 Wels	
				22 Wien	
				23 Wiener neustadt	
				24 Wolfsberg	
4	Azerbaijan	AZE		1 Əli bayramli	
				2 Baki	
				3 Bakixanov	
				4 Bilə cəri	
				5 Gəncə	
				6 Lənkəran	
				7 Mingəcevir	
				8 Naxcivan	
				9 Qaracuxur	
				10 Rəsulzadə	
				11 Səki	
				12 Sumqayit	
				13 Xankəndi	
				14 Yevlax	
5	Belgium	BEL		1 Aalst	
				2 Antwerpen	
				3 Beringen	
				4 Beveren	
				5 Brugge	
				6 Brussel	
				7 Charleroi	
				8 Dendermonde	
				9 Genk	
				10 Gent	
				11 Hasselt	
				12 Kortrijk	
				13 La louviere	
				14 Leuven	
				15 Liege	
				16 Mechelen	
				17 Mons	
				18 Mouscron	
				19 Namur	
				20 Oostende	
				21 Roeselare	
				22 Seraing	
				23 Sint-niklaas	
				24 Tournai	
				25 Verviers	

6	Bulgaria	BGR		<table border="1"> <tbody> <tr><td>1</td><td>Asenovgrad</td></tr> <tr><td>2</td><td>Blagoevgrad</td></tr> <tr><td>3</td><td>Burgas</td></tr> <tr><td>4</td><td>Dimitrovgrad</td></tr> <tr><td>5</td><td>Dobric</td></tr> <tr><td>6</td><td>Gabrovo</td></tr> <tr><td>7</td><td>Haskovo</td></tr> <tr><td>8</td><td>Jambol</td></tr> <tr><td>9</td><td>Kardzali</td></tr> <tr><td>10</td><td>Kazanlak</td></tr> <tr><td>11</td><td>Kjustendil</td></tr> <tr><td>12</td><td>Lovec</td></tr> <tr><td>13</td><td>Montana</td></tr> <tr><td>14</td><td>Pazardzik</td></tr> <tr><td>15</td><td>Pernik</td></tr> <tr><td>16</td><td>Pleven</td></tr> <tr><td>17</td><td>Plovdiv</td></tr> <tr><td>18</td><td>Ruse</td></tr> <tr><td>19</td><td>Sliven</td></tr> <tr><td>20</td><td>Sofija</td></tr> <tr><td>21</td><td>Stara zagora</td></tr> <tr><td>22</td><td>Sumen</td></tr> <tr><td>23</td><td>Targoviste</td></tr> <tr><td>24</td><td>Varna</td></tr> <tr><td>25</td><td>Veliko tarnovo</td></tr> <tr><td>26</td><td>Vidin</td></tr> <tr><td>27</td><td>Vraca</td></tr> </tbody> </table>	1	Asenovgrad	2	Blagoevgrad	3	Burgas	4	Dimitrovgrad	5	Dobric	6	Gabrovo	7	Haskovo	8	Jambol	9	Kardzali	10	Kazanlak	11	Kjustendil	12	Lovec	13	Montana	14	Pazardzik	15	Pernik	16	Pleven	17	Plovdiv	18	Ruse	19	Sliven	20	Sofija	21	Stara zagora	22	Sumen	23	Targoviste	24	Varna	25	Veliko tarnovo	26	Vidin	27	Vraca	
1	Asenovgrad																																																										
2	Blagoevgrad																																																										
3	Burgas																																																										
4	Dimitrovgrad																																																										
5	Dobric																																																										
6	Gabrovo																																																										
7	Haskovo																																																										
8	Jambol																																																										
9	Kardzali																																																										
10	Kazanlak																																																										
11	Kjustendil																																																										
12	Lovec																																																										
13	Montana																																																										
14	Pazardzik																																																										
15	Pernik																																																										
16	Pleven																																																										
17	Plovdiv																																																										
18	Ruse																																																										
19	Sliven																																																										
20	Sofija																																																										
21	Stara zagora																																																										
22	Sumen																																																										
23	Targoviste																																																										
24	Varna																																																										
25	Veliko tarnovo																																																										
26	Vidin																																																										
27	Vraca																																																										
7	Bosnia and Herzegovina	BIH		<table border="1"> <tbody> <tr><td>1</td><td>Banja luka</td></tr> <tr><td>2</td><td>Bihac</td></tr> <tr><td>3</td><td>Bijeljina</td></tr> <tr><td>4</td><td>Brcko</td></tr> <tr><td>5</td><td>Bugojno</td></tr> <tr><td>6</td><td>Cazin</td></tr> <tr><td>7</td><td>Doboj</td></tr> <tr><td>8</td><td>Mostar</td></tr> <tr><td>9</td><td>Prijedor</td></tr> <tr><td>10</td><td>Sarajevo</td></tr> <tr><td>11</td><td>Travnik</td></tr> <tr><td>12</td><td>Trebinje</td></tr> <tr><td>13</td><td>Tuzla</td></tr> <tr><td>14</td><td>Zenica</td></tr> </tbody> </table>	1	Banja luka	2	Bihac	3	Bijeljina	4	Brcko	5	Bugojno	6	Cazin	7	Doboj	8	Mostar	9	Prijedor	10	Sarajevo	11	Travnik	12	Trebinje	13	Tuzla	14	Zenica																											
1	Banja luka																																																										
2	Bihac																																																										
3	Bijeljina																																																										
4	Brcko																																																										
5	Bugojno																																																										
6	Cazin																																																										
7	Doboj																																																										
8	Mostar																																																										
9	Prijedor																																																										
10	Sarajevo																																																										
11	Travnik																																																										
12	Trebinje																																																										
13	Tuzla																																																										
14	Zenica																																																										
8	Belarus	BLR		<table border="1"> <tbody> <tr><td>1</td><td>Asipovicy</td></tr> <tr><td>2</td><td>Babruisk</td></tr> <tr><td>3</td><td>Baranavicy</td></tr> <tr><td>4</td><td>Barisaw</td></tr> <tr><td>5</td><td>Bjarose</td></tr> </tbody> </table>	1	Asipovicy	2	Babruisk	3	Baranavicy	4	Barisaw	5	Bjarose																																													
1	Asipovicy																																																										
2	Babruisk																																																										
3	Baranavicy																																																										
4	Barisaw																																																										
5	Bjarose																																																										

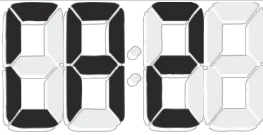
				6 Brest	
				7 Dzarzinsk	
				8 Homjel'	
				9 Horki	
				10 Hrodna	
				11 Kalinkavicy	
				12 Kobryn	
				13 Krycaw	
				14 Lida	
				15 Luninjec	
				16 Mahilyov	
				17 Maladzecna	
				18 Marjina horka	
				19 Mazyr	
				20 Minsk	
				21 Navahrudak	
				22 Navapolack	
				23 Orsa	
				24 Pastavy	
				25 Pinsk	
				26 Polack	
				27 Pruzany	
				28 Rahacov	
				29 Recyca	
				30 Salihorsk	
				31 Slonim	
				32 Sluck	
				33 Smarhon'	
				34 Svetlahorsk	
				35 Vawkavysk	
				36 Vicebsk	
				37 Viljejk	
				38 Zlobin	
				39 Zodzina	
9	Kazakhstan	KAZ		1 Akmecet	
				2 Aksu	
				3 Aktau	
				4 Aktobe	
				5 Almati	
				6 Arkalik	
				7 Astana	
				8 Atirau	
				9 Balkas	
				10 Baykonir	
				11 Canaozen	
				12 Canatas	

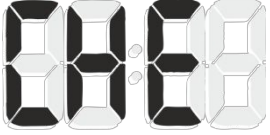
				13 Cetikara	
				14 Cezkazgan	
				15 Ekibastuz	
				16 Karaganda	
				17 Kentau	
				18 Koksetau	
				19 Kostanay	
				20 Oral	
				21 Oskemen	
				22 Pavlodar	
				23 Petropavl	
				24 Riddir	
				25 Rudni	
				26 Sahti	
				27 Saran	
				28 Satpaev	
				29 Scuce	
				30 Semey	
				31 Simkent	
				32 Stepnogorsk	
				33 Taldikorgan	
				34 Taraz	
				35 Temirtau	
				36 Turkistan	
				37 Ziryau	
10	Kyrgyzstan	KGZ		1 Balikci	
				2 Biskek	
				3 Celalabad	
				4 Carabalta	
				5 Karakol	
				6 Kizilkiya	
				7 Narin	
				8 Os	
				9 Ozgon	
				10 Talas	
				11 Tokmak	
11	Switzerland	CHE		1 Basel	
				2 Bern	
				3 White	
				4 Chur	
				5 Fribourg	
				6 Geneve	
				7 Koniz	
				8 La chaux-de-fonds	
				9 Lausanne	
				10 Luzern	

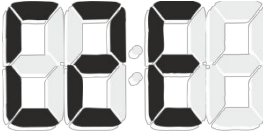
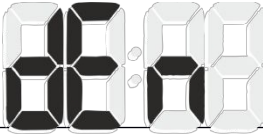
				11 Neuchatel	
				12 Sankt gallen	
				13 Schaffhausen	
				14 Thun	
				15 Winterthur	
				16 Zurich	
12	Cyprus	CYP		1 Gazimagusa	
				2 Girne	
				3 Guzelyurt	
				4 Larnaca	
				5 Lefkosa	
				6 Lefkosia	
				7 Lemesos	
				8 Pafos	
13	Czech Republic	CZE		1 Brno	
				2 Ceska linden	
				3 Ceske budejovice	
				4 Chomutov	
				5 Decin	
				6 Frýdek-místek	
				7 Havirov	
				8 Hradec kralove	
				9 Jablonec	
				10 Jihlava	
				11 Karlovy vary	
				12 Karvina	
				13 Kladno	
				14 Liberec	
				15 Mlada Boleslav	
				16 Bridge	
				17 Olomouc	
				18 Opava	
				19 Ostrava	
				20 Pardubice	
				21 Plzen	
				22 Praha	
				23 Prerov	
				24 Prostejov	
				25 Teplice	
				26 Trebic	
				27 Trinec	
				28 Usti	
				29 Zlin	
14	Dishes	DNK		1 Aalborg	
				2 Arhus	
				3 Esbjerg	

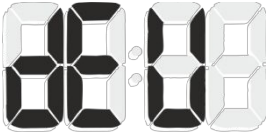
				4 Fredericia	
				5 Gentofte	
				6 Greve strand	
				7 Horsens	
				8 Horsholm	
				9 Kobenhavn	
				10 Kolding	
				11 Naestved	
				12 Odense	
				13 Randers	
				14 Roskilde	
				15 Silkeborg	
				16 Vejle	
15	Germany	DEU		1 Aachen	
				2 Augsburg	
				3 Bergisch gladbach	
				4 Berlin	
				5 Bielefeld	
				6 Bochum	
				7 Bonn	
				8 Bottrop	
				9 Braunschweig	
				10 Bremen	
				11 Bremerhaven	
				12 Chemnitz	
				13 Cottbus	
				14 Darmstadt	
				15 Dortmund	
				16 Dresden	
				17 Duisburg	
				18 Duren	
				19 Dusseldorf	
				20 Erfurt	
				21 Erlangen	
				22 Essen	
				23 Esslingen	
				24 Frankfurt	
				25 Freiburg	
				26 Furth	
				27 Gelsenkirchen	
				28 Gera	
				29 Gottingen	
				30 Gutersloh	
				31 Hagen	
				32 Halle	
				33 Hamburg	

				34	Hamm
				35	Hannover
				36	Heidelberg
				37	Heilbronn
				38	Herne
				39	Hildesheim
				40	Ingolstadt
				41	Iserlohn
				42	Jena
				43	Kaiserslautern
				44	Karlsruhe
				45	Kassel
				46	Kiel
				47	Koblenz
				48	Koln
				49	Krefeld
				50	Leipzig
				51	Leverkusen
				52	Lubeck
				53	Ludwigshafen
				54	Lunen
				55	Magdeburg
				56	Mainz
				57	Mannheim
				58	Marl
				59	Moers
				60	Monchengladbach
				61	Mulheim
				62	Munchen
				63	Munster
				64	Neuss
				65	Nurnberg
				66	Oberhausen
				67	Offenbach
				68	Oldenburg
				69	Osnabruck
				70	Paderborn
				71	Pforzheim
				72	Potsdam
				73	Ratingen
				74	Recklinghausen
				75	Regensburg
				76	Remscheid
				77	Reutlingen
				78	Rostock
				79	Saarbrucken

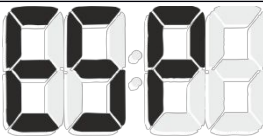
				80	Salzgitter
				81	Schwerin
				82	Siegen
				83	Solingen
				84	Stuttgart
				85	Trier
				86	Ulm
				87	Wiesbaden
				88	Witten
				89	Wolfsburg
				90	Wuppertal
				91	Wurzburg
				92	Zwickau
16	Spain	ESP		1	A coruna
				2	Alacant
				3	Albacete
				4	Alcala de henares
				5	Alcobendas
				6	Alcorcon
				7	Algeciras
				8	Algeciras
				9	Almeria
				10	Aviles
				11	Badajoz
				12	Badalona
				13	Barakaldo
				14	Barcelona
				15	Bilbao
				16	Burgos
				17	Caceres
				18	Cadiz
				19	Cartagena
				20	Castello
				21	Ceuta
				22	Cordoba
				23	Cornella
				24	Coslada
				25	Donostia
				26	Dos hermanas
				27	El puerto de santa maria
				28	Elx
				29	Ferrol
				30	Fuenlabrada
				31	Getafe
				32	Getxo
				33	Gijon

				34	Girona
				35	Granada
				36	Guadalajara
				37	Huelva
				38	Jaen
				39	Jerez
				40	Las palmas
				41	Las rozas de madrid
				42	Leganes
				43	Leon
				44	L'hospitalet de llobregat
				45	Lleida
				46	Logrono
				47	Lorca
				48	Lugo
				49	Madrid
				50	Malaga
				51	Marbella
				52	Mataro
				53	Mostoles
				54	Murcia
				55	Ourense
				56	Oviedo
				57	Palencia
				58	Palm
				59	Pamplona
				60	Parla
				61	Pontevedra
				62	Pozuelo de alarcon
				63	Reus
				64	Sabadell
				65	Salamanca
				66	San cristobal de la laguna
				67	San fernando
				68	San sebastian de los reyes
				69	Sant boi de llobregat
				70	Santa coloma de gramenet
				71	Santa cruz de tenerife
				72	Santander
				73	Santiago de compostela
				74	Sevilla
				75	Talavera de la reina
				76	Tarragona
				77	Telde

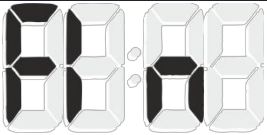
				78 Terrassa	
				79 Torrejon de ardoz	
				80 Valencia	
				81 Valladolid	
				82 Vigo	
				83 Vitoria	
				84 Zaragoza	
17	Estonia	EST		1 Kohtla-jarve	
				2 Kuressaare	
				3 Maardu	
				4 Narva	
				5 Parnu	
				6 Rakvere	
				7 Sillamae	
				8 Tallinn	
				9 Tartu	
				10 Valga	
				11 Viljandi	
				12 Voru	
18	Finland	FIN		1 Espoo	
				2 Hameenlinna	
				3 Helsinki	
				4 Hyvinkaa	
				5 Imatra	
				6 Jarvenpaa	
				7 Joensuu	
				8 Jyvaskyla	
				9 Kajaani	
				10 Kerava	
				11 Kirkkonummi	
				12 Kokkola	
				13 Catwoman	
				14 Kouvola	
				15 Kuopio	
				16 Lahti	
				17 Lappeenranta	
				18 Lohja	
				19 Mikkeli	
				20 Oulu	
				21 Pori	
				22 Porvoo	
				23 Rauma	
				24 Rovaniemi	
				25 Tampere	
				26 Turku	
				27 Tuusula	

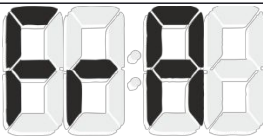
19	France	FRA		28	Vaasa
				29	Vantaa
				1	Aix-en-provence
				2	Amiens
				3	Angers
				4	Antibes
				5	Antony
				6	Argenteuil
				7	Asnieres-sur-seine
				8	Aubervillers
				9	Aulnay-sous-bois
				10	Avignon
				11	Beauvais
				12	Besancon
				13	Beziers
				14	Bordeaux
				15	Boulogne-billancourt
				16	Bourges
				17	Brest
				18	Caen
				19	Calais
				20	Cannes
				21	Cergy
				22	Chambery
				23	Champigny-sur-marne
				24	Charleville-mezieres
				25	Cholet
				26	Clermont-ferrand
				27	Colmar
				28	Colombes
				29	Courbevoie
				30	Creteil
				31	Dijon
				32	Drancy
				33	Dunkerque
				34	Grenoble
				35	Issy-les-moulineaux
				36	La rochelle
				37	La seyne-sur-mer
				38	Le havre
				39	Le mans
				40	Levallois-perret
				41	Lille
				42	Limoges
				43	Lorient
44	Lyon				

				45	Marseille
				46	Merignac
				47	Metz
				48	Montpellier
				49	Montreuil
				50	Mulhouse
				51	Nancy
				52	Nanterre
				53	Nantes
				54	Neuilly-sur-seine
				55	Nice
				56	Nimes
				57	Niort
				58	Noisy-le-grand
				59	Orleans
				60	Paris
				61	Pau
				62	Perpignan
				63	Pessac
				64	Poitiers
				65	Quimper
				66	Reims
				67	Rennes
				68	Roubaix
				69	Rouen
				70	Rueil-malmaison
				71	Saint-denis
				72	Saint-etienne
				73	Saint-malo
				74	Saint-maur-des-fosses
				75	Saint-nazaire
				76	Saint-quentin
				77	Sarcelles
				78	Strasbourg
				79	Toulon
				80	Toulouse
				81	Tourcoing
				82	Tours
				83	Troyes
				84	Valence
				85	Vannes
				86	Venissieux
				87	Versailles
				88	Villeneuve-d'ascq
				89	Villeurbanne
				90	Vitry-sur-seine

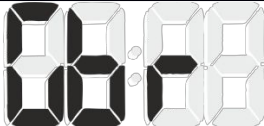
20	<p>United Kingdom</p>	GBR		<table border="1"> <tr><td>1</td><td>Aberdeen</td></tr> <tr><td>2</td><td>Basildon</td></tr> <tr><td>3</td><td>Belfast</td></tr> <tr><td>4</td><td>Birmingham</td></tr> <tr><td>5</td><td>Blackburn</td></tr> <tr><td>6</td><td>Blackpool</td></tr> <tr><td>7</td><td>Bolton</td></tr> <tr><td>8</td><td>Bournemouth</td></tr> <tr><td>9</td><td>Bradford</td></tr> <tr><td>10</td><td>Brighton</td></tr> <tr><td>11</td><td>Bristol</td></tr> <tr><td>12</td><td>Cambridge</td></tr> <tr><td>13</td><td>Cardiff</td></tr> <tr><td>14</td><td>Chelmsford</td></tr> <tr><td>15</td><td>Colchester</td></tr> <tr><td>16</td><td>Coventry</td></tr> <tr><td>17</td><td>Derby</td></tr> <tr><td>18</td><td>Dudley</td></tr> <tr><td>19</td><td>Dundee</td></tr> <tr><td>20</td><td>Eastbourne</td></tr> <tr><td>21</td><td>Edinburgh</td></tr> <tr><td>22</td><td>Exeter</td></tr> <tr><td>23</td><td>Glasgow</td></tr> <tr><td>24</td><td>Gloucester</td></tr> <tr><td>25</td><td>Huddersfield</td></tr> <tr><td>26</td><td>Ipswich</td></tr> <tr><td>27</td><td>Kingston upon hull</td></tr> <tr><td>28</td><td>Leeds</td></tr> <tr><td>29</td><td>Leicester</td></tr> <tr><td>30</td><td>Liverpool</td></tr> <tr><td>31</td><td>London</td></tr> <tr><td>32</td><td>Luton</td></tr> <tr><td>33</td><td>Manchester</td></tr> <tr><td>34</td><td>Middlesbrough</td></tr> <tr><td>35</td><td>Motherwell</td></tr> <tr><td>36</td><td>Newcastle upon tyne</td></tr> <tr><td>37</td><td>Newport</td></tr> <tr><td>38</td><td>Northampton</td></tr> <tr><td>39</td><td>Norwich</td></tr> <tr><td>40</td><td>Nottingham</td></tr> <tr><td>41</td><td>Oldbury-smethwick</td></tr> <tr><td>42</td><td>Oldham</td></tr> <tr><td>43</td><td>Oxford</td></tr> <tr><td>44</td><td>Peterborough</td></tr> <tr><td>45</td><td>Plymouth</td></tr> <tr><td>46</td><td>Poole</td></tr> </table>	1	Aberdeen	2	Basildon	3	Belfast	4	Birmingham	5	Blackburn	6	Blackpool	7	Bolton	8	Bournemouth	9	Bradford	10	Brighton	11	Bristol	12	Cambridge	13	Cardiff	14	Chelmsford	15	Colchester	16	Coventry	17	Derby	18	Dudley	19	Dundee	20	Eastbourne	21	Edinburgh	22	Exeter	23	Glasgow	24	Gloucester	25	Huddersfield	26	Ipswich	27	Kingston upon hull	28	Leeds	29	Leicester	30	Liverpool	31	London	32	Luton	33	Manchester	34	Middlesbrough	35	Motherwell	36	Newcastle upon tyne	37	Newport	38	Northampton	39	Norwich	40	Nottingham	41	Oldbury-smethwick	42	Oldham	43	Oxford	44	Peterborough	45	Plymouth	46	Poole	
1	Aberdeen																																																																																																
2	Basildon																																																																																																
3	Belfast																																																																																																
4	Birmingham																																																																																																
5	Blackburn																																																																																																
6	Blackpool																																																																																																
7	Bolton																																																																																																
8	Bournemouth																																																																																																
9	Bradford																																																																																																
10	Brighton																																																																																																
11	Bristol																																																																																																
12	Cambridge																																																																																																
13	Cardiff																																																																																																
14	Chelmsford																																																																																																
15	Colchester																																																																																																
16	Coventry																																																																																																
17	Derby																																																																																																
18	Dudley																																																																																																
19	Dundee																																																																																																
20	Eastbourne																																																																																																
21	Edinburgh																																																																																																
22	Exeter																																																																																																
23	Glasgow																																																																																																
24	Gloucester																																																																																																
25	Huddersfield																																																																																																
26	Ipswich																																																																																																
27	Kingston upon hull																																																																																																
28	Leeds																																																																																																
29	Leicester																																																																																																
30	Liverpool																																																																																																
31	London																																																																																																
32	Luton																																																																																																
33	Manchester																																																																																																
34	Middlesbrough																																																																																																
35	Motherwell																																																																																																
36	Newcastle upon tyne																																																																																																
37	Newport																																																																																																
38	Northampton																																																																																																
39	Norwich																																																																																																
40	Nottingham																																																																																																
41	Oldbury-smethwick																																																																																																
42	Oldham																																																																																																
43	Oxford																																																																																																
44	Peterborough																																																																																																
45	Plymouth																																																																																																
46	Poole																																																																																																

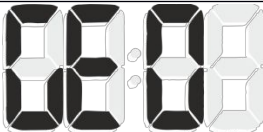
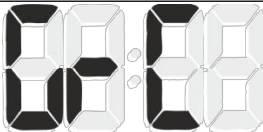

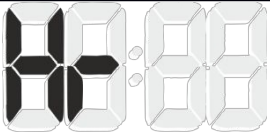
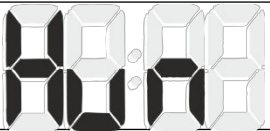
				47 Portsmouth	
				48 Preston	
				49 Reading	
				50 Rotherham	
				51 Saint helens	
				52 Sheffield	
				53 Slough	
				54 Southampton	
				55 Southend-on-sea	
				56 Stockport	
				57 Stoke-on-trent	
				58 Sunderland	
				59 Sutton coldfield	
				60 Swansea	
				61 Swindon	
				62 Walsall	
				63 Watford	
				64 West bromwich	
				65 Woking-byfleet	
				66 Wolverhampton	
				67 Worthing	
				68 York	
21	Georgia	GEO		1 Batumi	
				2 Gori	
				3 Kutaisi	
				4 Poti	
				5 Rustavi	
				6 Sukhumi	
				7 Tbilisi	
				8 Tskhinvali	
				9 Zugdidi	
22	Greece	GRC		1 Aigaleo	
				2 Akharnai	
				3 Alexandroupoli	
				4 Amarousion	
				5 Athinai	
				6 Ayia paraskevi	
				7 Ayios dimitrios	
				8 Euosmon	
				9 Galatsion	
				10 Glyphada	
				11 Ilion	
				12 Ilioupoli	
				13 Ioannina	
				14 Iraklion	
				15 Kalamaria	

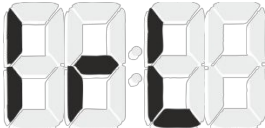
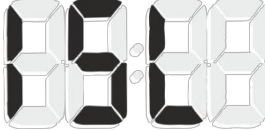
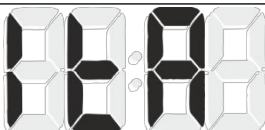
				16 Kalamata	
				17 Kallithea	
				18 Katerini	
				19 Kavala	
				20 Keratsinion	
				21 Khalandrion	
				22 Khalkis	
				23 Khandia	
				24 Koridallos	
				25 Larisa	
				26 Nea ionia	
				27 Nea smirni	
				28 Nikaia	
				29 Palaion faliron	
				30 Patrai	
				31 Peristerion	
				32 Piraius	
				33 Rhodes	
				34 Serrai	
				35 Thessaloniki	
				36 Viron	
				37 Volos	
				38 Zografos	
23	Croatia	HRV		1 Bjelovar	
				2 Dakovo	
				3 Dubrovnik	
				4 Karlovac	
				5 Koprivnica	
				6 Osijek	
				7 Pozega	
				8 Pool	
				9 Rijeka	
				10 Sesvete	
				11 Sibenik	
				12 Sisak	
				13 Slavonski brod	
				14 Split	
				15 Varazdin	
				16 Velika gorica	
				17 Vinkovci	
				18 Vukovar	
				19 Zadar	
				20 Zagreb	
24	Hungary	HUN		1 Bekescsaba	
				2 Budapest	
				3 Debrecen	

				<ul style="list-style-type: none"> 4 Dunaujvaros 5 Eger 6 Erd 7 Győr 8 Kaposvár 9 Kecskemét 10 Miskolc 11 Nagykanizsa 12 Nyiregyháza 13 Pécs 14 Sopron 15 Szeged 16 Szekesfehervar 17 Szolnok 18 Szombathely 19 Tatabánya 20 Veszprem 21 Zalaegerszeg 	
25	Ireland	IRL		<ul style="list-style-type: none"> 1 Bray 2 Cork 3 Drogheda 4 Dublin 5 Dundalk 6 Ennis 7 Galway 8 Kilkenny 9 Limerick 10 Swords 11 Tralee 12 Waterford 	
26	Iceland	ISL		<ul style="list-style-type: none"> 1 Akranes 2 Akureyri 3 Gardabaer 4 Hafnarfjörður 5 Keflavik 6 Kopavogur 7 Mosfellsbaer 8 Reykjavik 9 Selfoss 10 Seltjarnarnes 	
27	Italy	ITA		<ul style="list-style-type: none"> 1 Alessandria 2 Ancona 3 Andria 4 Arezzo 5 Asti 6 Bari 	

				7	Barletta
				8	Bergamo
				9	Bologna
				10	Bolzano
				11	Brescia
				12	Brindisi
				13	Busto arsizio
				14	Cagliari
				15	Caserta
				16	Casoria
				17	Catania
				18	Catanzaro
				19	Cesena
				20	Cinisello balsamo
				21	Como
				22	Cosenza
				23	Cremona
				24	Ferrara
				25	Firenze
				26	Foggia
				27	ForlāCE
				28	Gela
				29	Genova
				30	Giugliano in campania
				31	Grosseto
				32	Guidonia
				33	La spezia
				34	Latina
				35	Lecce
				36	Livorno
				37	Lucca
				38	Marsala
				39	Messina
				40	Milano
				41	Modena
				42	Monza
				43	Napoli
				44	Novara
				45	Padova
				46	Palermo
				47	Parma
				48	Pavia
				49	Perugia
				50	Pesaro
				51	Pescara
				52	Piacenza

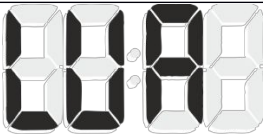
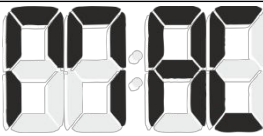
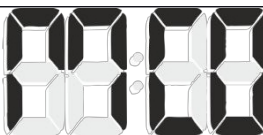
				<table border="1"> <tbody> <tr><td>53</td><td>Pisa</td></tr> <tr><td>54</td><td>Pistoia</td></tr> <tr><td>55</td><td>Pozzuoli</td></tr> <tr><td>56</td><td>Prato</td></tr> <tr><td>57</td><td>Ragusa</td></tr> <tr><td>58</td><td>Ravenna</td></tr> <tr><td>59</td><td>Reggio di calabria</td></tr> <tr><td>60</td><td>Reggio nell'emilia</td></tr> <tr><td>61</td><td>Rimini</td></tr> <tr><td>62</td><td>Roma</td></tr> <tr><td>63</td><td>Salerno</td></tr> <tr><td>64</td><td>Sassari</td></tr> <tr><td>65</td><td>Sesto san giovanni</td></tr> <tr><td>66</td><td>Siracusa</td></tr> <tr><td>67</td><td>Taranto</td></tr> <tr><td>68</td><td>Terni</td></tr> <tr><td>69</td><td>Torino</td></tr> <tr><td>70</td><td>Torre del greco</td></tr> <tr><td>71</td><td>Trento</td></tr> <tr><td>72</td><td>Treviso</td></tr> <tr><td>73</td><td>Trieste</td></tr> <tr><td>74</td><td>Udine</td></tr> <tr><td>75</td><td>Varese</td></tr> <tr><td>76</td><td>Venezia</td></tr> <tr><td>77</td><td>Verona</td></tr> <tr><td>78</td><td>Vicenza</td></tr> </tbody> </table>	53	Pisa	54	Pistoia	55	Pozzuoli	56	Prato	57	Ragusa	58	Ravenna	59	Reggio di calabria	60	Reggio nell'emilia	61	Rimini	62	Roma	63	Salerno	64	Sassari	65	Sesto san giovanni	66	Siracusa	67	Taranto	68	Terni	69	Torino	70	Torre del greco	71	Trento	72	Treviso	73	Trieste	74	Udine	75	Varese	76	Venezia	77	Verona	78	Vicenza	
53	Pisa																																																								
54	Pistoia																																																								
55	Pozzuoli																																																								
56	Prato																																																								
57	Ragusa																																																								
58	Ravenna																																																								
59	Reggio di calabria																																																								
60	Reggio nell'emilia																																																								
61	Rimini																																																								
62	Roma																																																								
63	Salerno																																																								
64	Sassari																																																								
65	Sesto san giovanni																																																								
66	Siracusa																																																								
67	Taranto																																																								
68	Terni																																																								
69	Torino																																																								
70	Torre del greco																																																								
71	Trento																																																								
72	Treviso																																																								
73	Trieste																																																								
74	Udine																																																								
75	Varese																																																								
76	Venezia																																																								
77	Verona																																																								
78	Vicenza																																																								
28	Lichtenstein	LIE		<table border="1"> <tbody> <tr><td>1</td><td>Schaan</td></tr> </tbody> </table>	1	Schaan																																																			
1	Schaan																																																								
29	Lithuania	LTU		<table border="1"> <tbody> <tr><td>1</td><td>Alytus</td></tr> <tr><td>2</td><td>Jonava</td></tr> <tr><td>3</td><td>Kaunas</td></tr> <tr><td>4</td><td>Kedainiai</td></tr> <tr><td>5</td><td>Klaipeda</td></tr> <tr><td>6</td><td>Marijampole</td></tr> <tr><td>7</td><td>Mazeikiai</td></tr> <tr><td>8</td><td>Panevezys</td></tr> <tr><td>9</td><td>Siauliai</td></tr> <tr><td>10</td><td>Telsiai</td></tr> <tr><td>11</td><td>Utena</td></tr> <tr><td>12</td><td>Vilnius</td></tr> </tbody> </table>	1	Alytus	2	Jonava	3	Kaunas	4	Kedainiai	5	Klaipeda	6	Marijampole	7	Mazeikiai	8	Panevezys	9	Siauliai	10	Telsiai	11	Utena	12	Vilnius																													
1	Alytus																																																								
2	Jonava																																																								
3	Kaunas																																																								
4	Kedainiai																																																								
5	Klaipeda																																																								
6	Marijampole																																																								
7	Mazeikiai																																																								
8	Panevezys																																																								
9	Siauliai																																																								
10	Telsiai																																																								
11	Utena																																																								
12	Vilnius																																																								
30	Luxemburg	LUX		<table border="1"> <tbody> <tr><td>1</td><td>Luxembourg</td></tr> </tbody> </table>	1	Luxembourg																																																			
1	Luxembourg																																																								

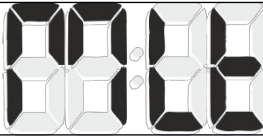
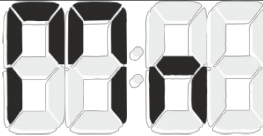
31	Latvia	LVA		<table border="1"> <tbody> <tr><td>1</td><td>Cesis</td></tr> <tr><td>2</td><td>Daugavpils</td></tr> <tr><td>3</td><td>Jekabspils</td></tr> <tr><td>4</td><td>Jelgava</td></tr> <tr><td>5</td><td>Jurmala</td></tr> <tr><td>6</td><td>Liepaja</td></tr> <tr><td>7</td><td>Ogre</td></tr> <tr><td>8</td><td>Rezekne</td></tr> <tr><td>9</td><td>Riga</td></tr> <tr><td>10</td><td>Salaspils</td></tr> <tr><td>11</td><td>Tukums</td></tr> <tr><td>12</td><td>Valmiera</td></tr> <tr><td>13</td><td>Ventspils</td></tr> </tbody> </table>	1	Cesis	2	Daugavpils	3	Jekabspils	4	Jelgava	5	Jurmala	6	Liepaja	7	Ogre	8	Rezekne	9	Riga	10	Salaspils	11	Tukums	12	Valmiera	13	Ventspils
1	Cesis																													
2	Daugavpils																													
3	Jekabspils																													
4	Jelgava																													
5	Jurmala																													
6	Liepaja																													
7	Ogre																													
8	Rezekne																													
9	Riga																													
10	Salaspils																													
11	Tukums																													
12	Valmiera																													
13	Ventspils																													
32	Macedonia	MKD		<table border="1"> <tbody> <tr><td>1</td><td>Bitola</td></tr> <tr><td>2</td><td>Kumanovo</td></tr> <tr><td>3</td><td>Ohrid</td></tr> <tr><td>4</td><td>Prilep</td></tr> <tr><td>5</td><td>Skopje</td></tr> <tr><td>6</td><td>Tetovo</td></tr> <tr><td>7</td><td>Veles</td></tr> </tbody> </table>	1	Bitola	2	Kumanovo	3	Ohrid	4	Prilep	5	Skopje	6	Tetovo	7	Veles												
1	Bitola																													
2	Kumanovo																													
3	Ohrid																													
4	Prilep																													
5	Skopje																													
6	Tetovo																													
7	Veles																													
33	Monaco	MCO		<table border="1"> <tbody> <tr><td>1</td><td>Monte carlo</td></tr> </tbody> </table>	1	Monte carlo																								
1	Monte carlo																													
34	Moldova	MDA		<table border="1"> <tbody> <tr><td>1</td><td>Balti</td></tr> <tr><td>2</td><td>Cahul</td></tr> <tr><td>3</td><td>Chisinau</td></tr> <tr><td>4</td><td>Rabnita</td></tr> <tr><td>5</td><td>Tighina</td></tr> <tr><td>6</td><td>Tiraspol'</td></tr> </tbody> </table>	1	Balti	2	Cahul	3	Chisinau	4	Rabnita	5	Tighina	6	Tiraspol'														
1	Balti																													
2	Cahul																													
3	Chisinau																													
4	Rabnita																													
5	Tighina																													
6	Tiraspol'																													
35	Malta	MLT		<table border="1"> <tbody> <tr><td>1</td><td>Birkirkara</td></tr> </tbody> </table>	1	Birkirkara																								
1	Birkirkara																													
36	Mongolia	MNG		<table border="1"> <tbody> <tr><td>1</td><td>Arvajheer</td></tr> <tr><td>2</td><td>Bajanhongor</td></tr> <tr><td>3</td><td>Cojbalsan</td></tr> <tr><td>4</td><td>Darhan</td></tr> <tr><td>5</td><td>Erdenet</td></tr> <tr><td>6</td><td>Hovd</td></tr> <tr><td>7</td><td>Moron</td></tr> <tr><td>8</td><td>Olgj</td></tr> <tr><td>9</td><td>Sajnsand</td></tr> <tr><td>10</td><td>Suhbaatar</td></tr> <tr><td>11</td><td>Ulaanbaatar</td></tr> <tr><td>12</td><td>Ulaangom</td></tr> <tr><td>13</td><td>Uliastaj</td></tr> </tbody> </table>	1	Arvajheer	2	Bajanhongor	3	Cojbalsan	4	Darhan	5	Erdenet	6	Hovd	7	Moron	8	Olgj	9	Sajnsand	10	Suhbaatar	11	Ulaanbaatar	12	Ulaangom	13	Uliastaj
1	Arvajheer																													
2	Bajanhongor																													
3	Cojbalsan																													
4	Darhan																													
5	Erdenet																													
6	Hovd																													
7	Moron																													
8	Olgj																													
9	Sajnsand																													
10	Suhbaatar																													
11	Ulaanbaatar																													
12	Ulaangom																													
13	Uliastaj																													

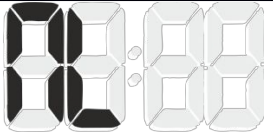
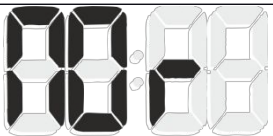
37	Netherlands	NLD		<table border="1"> <tbody> <tr><td>1</td><td>Almere</td></tr> <tr><td>2</td><td>Amersfoort</td></tr> <tr><td>3</td><td>Amsterdam</td></tr> <tr><td>4</td><td>Apeldoorn</td></tr> <tr><td>5</td><td>Arnhem</td></tr> <tr><td>6</td><td>Breda</td></tr> <tr><td>7</td><td>Dordrecht</td></tr> <tr><td>8</td><td>Ede</td></tr> <tr><td>9</td><td>Eindhoven</td></tr> <tr><td>10</td><td>Emmen</td></tr> <tr><td>11</td><td>Enschede</td></tr> <tr><td>12</td><td>Groningen</td></tr> <tr><td>13</td><td>Haarlem</td></tr> <tr><td>14</td><td>Haarlemmermeer</td></tr> <tr><td>15</td><td>Leiden</td></tr> <tr><td>16</td><td>Maastricht</td></tr> <tr><td>17</td><td>Nijmegen</td></tr> <tr><td>18</td><td>Rotterdam</td></tr> <tr><td>19</td><td>'s-gravenhage</td></tr> <tr><td>20</td><td>'s-hertogenbosch</td></tr> <tr><td>21</td><td>Tilburg</td></tr> <tr><td>22</td><td>Utrecht</td></tr> <tr><td>23</td><td>Zaanstad</td></tr> <tr><td>24</td><td>Zoetermeer</td></tr> <tr><td>25</td><td>Zwolle</td></tr> </tbody> </table>	1	Almere	2	Amersfoort	3	Amsterdam	4	Apeldoorn	5	Arnhem	6	Breda	7	Dordrecht	8	Ede	9	Eindhoven	10	Emmen	11	Enschede	12	Groningen	13	Haarlem	14	Haarlemmermeer	15	Leiden	16	Maastricht	17	Nijmegen	18	Rotterdam	19	's-gravenhage	20	's-hertogenbosch	21	Tilburg	22	Utrecht	23	Zaanstad	24	Zoetermeer	25	Zwolle	
1	Almere																																																						
2	Amersfoort																																																						
3	Amsterdam																																																						
4	Apeldoorn																																																						
5	Arnhem																																																						
6	Breda																																																						
7	Dordrecht																																																						
8	Ede																																																						
9	Eindhoven																																																						
10	Emmen																																																						
11	Enschede																																																						
12	Groningen																																																						
13	Haarlem																																																						
14	Haarlemmermeer																																																						
15	Leiden																																																						
16	Maastricht																																																						
17	Nijmegen																																																						
18	Rotterdam																																																						
19	's-gravenhage																																																						
20	's-hertogenbosch																																																						
21	Tilburg																																																						
22	Utrecht																																																						
23	Zaanstad																																																						
24	Zoetermeer																																																						
25	Zwolle																																																						
38	Norway	NOR		<table border="1"> <tbody> <tr><td>1</td><td>Alesund</td></tr> <tr><td>2</td><td>Alta</td></tr> <tr><td>3</td><td>Arendal</td></tr> <tr><td>4</td><td>Askim</td></tr> <tr><td>5</td><td>Askoy</td></tr> <tr><td>6</td><td>Bergen</td></tr> <tr><td>7</td><td>Bodo</td></tr> <tr><td>8</td><td>Drammen</td></tr> <tr><td>9</td><td>Drobak</td></tr> <tr><td>10</td><td>Elverum</td></tr> <tr><td>11</td><td>Fredrikstad-sarpsborg</td></tr> <tr><td>12</td><td>Gjovik</td></tr> <tr><td>13</td><td>Halden</td></tr> <tr><td>14</td><td>Hamar</td></tr> <tr><td>15</td><td>Harstad</td></tr> <tr><td>16</td><td>Haugesund</td></tr> <tr><td>17</td><td>Honefoss</td></tr> <tr><td>18</td><td>Horten</td></tr> <tr><td>19</td><td>Jessheim</td></tr> <tr><td>20</td><td>Kongsberg</td></tr> <tr><td>21</td><td>Kongsvinger</td></tr> </tbody> </table>	1	Alesund	2	Alta	3	Arendal	4	Askim	5	Askoy	6	Bergen	7	Bodo	8	Drammen	9	Drobak	10	Elverum	11	Fredrikstad-sarpsborg	12	Gjovik	13	Halden	14	Hamar	15	Harstad	16	Haugesund	17	Honefoss	18	Horten	19	Jessheim	20	Kongsberg	21	Kongsvinger									
1	Alesund																																																						
2	Alta																																																						
3	Arendal																																																						
4	Askim																																																						
5	Askoy																																																						
6	Bergen																																																						
7	Bodo																																																						
8	Drammen																																																						
9	Drobak																																																						
10	Elverum																																																						
11	Fredrikstad-sarpsborg																																																						
12	Gjovik																																																						
13	Halden																																																						
14	Hamar																																																						
15	Harstad																																																						
16	Haugesund																																																						
17	Honefoss																																																						
18	Horten																																																						
19	Jessheim																																																						
20	Kongsberg																																																						
21	Kongsvinger																																																						

				22	Kristiansand
				23	Kristiansund
				24	Larvik
				25	Leirvik
				26	Lillehammer
				27	Mandal
				28	Mo and wound
				29	Molde
				30	Moss
				31	Narvik
				32	Nesoddtangen
				33	Oslo
				34	Porsgrunn-skien
				35	SandeŊord
				36	Ski
				37	Stavanger
				38	Steinkjer
				39	Tonsberg
				40	Tromso
				41	Trondheim
				42	Vennesla
39	Poland	POL		1	Aleksandrów Kujawski
				2	Aleksandrów Łódzki
				3	Annopol
				4	Augustów
				5	Białystok
				6	Bielsko-Biała
				7	Bydgoszcz
				8	Bytom
				9	Chelmża
				10	Cieszyn
				11	Duszniki Zdrój
				12	Elbląg
				13	Elk
				14	Frombork
				15	Gdansk
				16	Giżycko
				17	Gliwice
				18	Gostynin
				19	Hel
				20	Hrubieszów
				21	Ilawa
				22	Jarocin
				23	Jaslo
				24	Jelenia Góra
				25	Kalisz

				26	Katowice
				27	Kielce
				28	Kluczbork
				29	Kolobrzeg
				30	Koszalin
				31	Krakow
				32	Krynica
				33	Leszno
				34	Lubaczów
				35	Lublin
				36	Lubomierz
				37	Łańcut
				38	Łeba
				39	Łomianki
				40	Łowicz
				41	Łódź
				42	Mrągowo
				43	Mysłowice
				44	Naklo nad Notcią
				45	Nidzica
				46	Nowy Sącz
				47	Nysa
				48	Olsztyn
				49	Opole
				50	Ostrołęka
				51	Ostrowiec Świętokrzyski
				52	Ostrów Mazowiecki
				53	Auschwitz
				54	Ozorków
				55	Plock
				56	Polanica Zdrój
				57	Poznan
				58	Puck
				59	Radzymin
				60	Rzeszów
				61	Sanok
				62	Sieradz
				63	Siewierz
				64	Skawina
				65	Słubice
				66	Sochaczew
				67	Solec Kujawski
				68	Sosnowiec
				69	Stalowa Wola
				70	Stary Sącz
				71	Szczecin

				72 Swidnica	
				73 Tarnowskie Góry	
				74 Tarnów	
				75 Torun	
				76 Tychy	
				77 Ustrzyki Dolne	
				78 Walcz	
				79 Warsaw	
				80 Wieliczka	
				81 Wrocław	
				82 September	
				83 Zakopane	
				84 Zawiercie	
				85 Zielona Góra	
				86 Żywiec	
40	Portugal	PRT		1 Agualva-cacem	
				2 Alcabideche	
				3 Algueirao-mem martins	
				4 Almada	
				5 Amadora	
				6 Amora	
				7 Aveiro	
				8 Barreiro	
				9 Braga	
				10 Camara de lobos	
				11 Cascais	
				12 Castelo branco	
				13 Coimbra	
				14 Corroios	
				15 Ermesinde	
				16 Evora	
				17 Faro	
				18 Funchal	
				19 Guimaraes	
				20 Leiria	
				21 Lisboa	
				22 Loures	
				23 Maia	
				24 Odivelas	
				25 Oeiras e sao juliao da barra	
				26 Portimao	
				27 Porto	
				28 Queluz	
				29 Rio de mouro	
				30 Rio tinto	

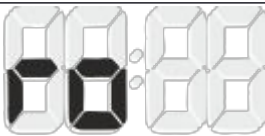
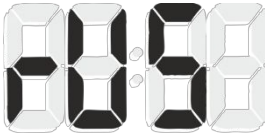
				31 Sao domingos de rana	
				32 Sesimbra	
				33 Setubal	
				34 Vila nova de gaia	
41	Romania	RO		1 Arad	
				2 Bacau	
				3 Baia mare	
				4 Botosani	
				5 Braila	
				6 Brasov	
				7 Bucuresti	
				8 Buzau	
				9 Cluj-napoca	
				10 Constanta	
				11 Craiova	
				12 Drobeta-turnu severin	
				13 Focsani	
				14 Galati	
				15 Iasi	
				16 Oradea	
				17 Piatra neamt	
				18 Pitesti	
				19 Ploiesti	
				20 Ramnicu valcea	
				21 Satu mare	
				22 Sibiu	
				23 Suceava	
				24 Targu-mures	
				25 Timisoara	
42	Russia	RUS		1 Angarsk	
				2 Arhangelsk	
				3 Armavir	
				4 Astrakhan	
				5 Balakovo	
				6 Barnaul	
				7 Belgorod	
				8 Bijsk	
				9 Blagovescensk	
				10 Bratsk	
				11 Brjansk	
				12 Ceboksary	
				13 Cerepovec	
				14 Chelyabinsk	
				15 Cita	
				16 Dzerzinsk	
				17 Engels	
				18 Groznyj	

				19	Habarovsk
				20	Irkutsk
				21	Ivanovo
				22	Izhevsk
				23	Yakutsk
				24	Yekaterinburg
				25	Joskar-ola
				26	Kaliningrad
				27	Kaluga
				28	Kamensk-uralskij
				29	Kazan
				30	Kemerovo
				31	Kirov
				32	Komsomolsk-na-amure
				33	Kostroma
				34	Krasnodar
				35	Krasnoyarsk
				36	Kurgan
				37	Kursk
				38	Lipetsk
				39	Magnitogorsk
				40	Makhackala
				41	Moskva
				42	Murmansk
				43	Naberezhnye Chelny
				44	Nalcik
				45	Niznekamsk
				46	Niznevartovsk
				47	Niznij novgorod
				48	Niznij tagil
				49	Novokuznetsk
				50	Novorossiysk
				51	Novosibirsk
				52	Omsk
				53	Orenburg
				54	Orjol
				55	Orsk
				56	Penza
				57	Perm
				58	Petropavlovsk-kamcat- skij
				59	Petrozavodsk
				60	Prokopjevsk
				61	Pskov
				62	Rjazan
				63	Rostov

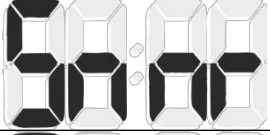
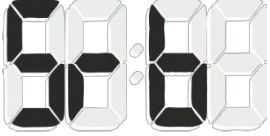
				64 Rybinsk	
				65 Sahty	
				66 Samara	
				67 Sankt-peterburg	
				68 Saransk	
				69 Saratov	
				70 Severodvinsk	
				71 Smolensk	
				72 Soci	
				73 Staryj oskol	
				74 Stavropol	
				75 Sterlitamak	
				76 Surgut	
				77 Syktyvkar	
				78 Syzran	
				79 Taganrog	
				80 Tambov	
				81 Tolyatti	
				82 Tomsk	
				83 Tula	
				84 Tver	
				85 Tyumen	
				86 Ufa	
				87 Ulan-ude	
				88 Ulyanovsk	
				89 Velikij novgorod	
				90 Vladikavkaz	
				91 Vladimir	
				92 Vladivostok	
				93 Volgograd	
				94 Vologda	
				95 Volzskij	
				96 Voronezh	
				97 Yaroslavl	
				98 Zelenograd	
				99 Zlatoust	
43	San Marino	SMR		1 San marino	
44	Serbia	SRB		1 Beograd	
				2 Pristina	
				3 Novi sad	
				4 Nis	
				5 Kragujevac	
				6 Podgorica	
				7 Prizren	

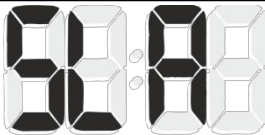
				8 Subotica	
				9 Pec	
				10 Zrenjanin	
				11 Dakovica	
				12 Kosovska mitrovica	
				13 Pancevo	
				14 Cacak	
				15 Gnjilane	
				16 Leskovac	
				17 Smederevo	
				18 Niksic	
				19 Valjevo	
				20 Kraljevo	
				21 Krusevac	
				22 Uzice	
				23 Vranje	
				24 Sabac	
				25 Novi pazar	
				26 Sombor	
45	Slovakia	SVK		1 Bratislava	
				2 Kosice	
				3 Presov	
				4 Nitra	
				5 Zilina	
				6 Banska bystrica	
				7 Trnava	
				8 Martin	
				9 Trencin	
				10 Poprad	
				11 Prievidza	
				12 Zvolen	
				13 Povazska bystrica	
				14 Nove zamky	
				15 Spisska nova ves	
				16 Michalovce	
				17 Komarno	
				18 Levice	
				19 Humenne	
				20 Bardejov	
46	Slovenia	SVN		1 Ljubljana	
				2 Maribor	
				3 Celje	
				4 Kranj	
				5 Velenje	
				6 Dill	
				7 Novo mesto	

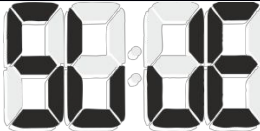
48	Sweden	SWE		<table border="1"> <tr><td>1</td><td>Akersberga</td></tr> <tr><td>2</td><td>Alingsas</td></tr> <tr><td>3</td><td>Angelholm</td></tr> <tr><td>4</td><td>Boras</td></tr> <tr><td>5</td><td>Borlange</td></tr> <tr><td>6</td><td>Eskilstuna</td></tr> <tr><td>7</td><td>Falun</td></tr> <tr><td>8</td><td>Gavle</td></tr> <tr><td>9</td><td>Goteborg</td></tr> <tr><td>10</td><td>Halmstad</td></tr> <tr><td>11</td><td>Helsingborg</td></tr> <tr><td>12</td><td>Jonkoping</td></tr> <tr><td>13</td><td>Kalmar</td></tr> <tr><td>14</td><td>Karlskoga</td></tr> <tr><td>15</td><td>Karlskrona</td></tr> <tr><td>16</td><td>Karlstad</td></tr> <tr><td>17</td><td>Kristianstad</td></tr> <tr><td>18</td><td>Landskrona</td></tr> <tr><td>19</td><td>Lidingo</td></tr> <tr><td>20</td><td>Lidkoping</td></tr> <tr><td>21</td><td>Linkoping</td></tr> <tr><td>22</td><td>Lulea</td></tr> <tr><td>23</td><td>Lund</td></tr> <tr><td>24</td><td>Malmo</td></tr> <tr><td>25</td><td>Marsta</td></tr> <tr><td>26</td><td>Motala</td></tr> <tr><td>27</td><td>Norrkoping</td></tr> <tr><td>28</td><td>Nykoping</td></tr> <tr><td>29</td><td>Orebro</td></tr> <tr><td>30</td><td>Ornskoldsvik</td></tr> <tr><td>31</td><td>Ostersund</td></tr> <tr><td>32</td><td>Pitea</td></tr> <tr><td>33</td><td>Sandviken</td></tr> <tr><td>34</td><td>Skelleftea</td></tr> <tr><td>35</td><td>Skovde</td></tr> <tr><td>36</td><td>Sodertalje</td></tr> <tr><td>37</td><td>Stockholm</td></tr> <tr><td>38</td><td>Sundsvall</td></tr> <tr><td>39</td><td>Tabas</td></tr> <tr><td>40</td><td>Trelleborg</td></tr> <tr><td>41</td><td>Trollhattan</td></tr> <tr><td>42</td><td>Tumba</td></tr> <tr><td>43</td><td>Uddevalla</td></tr> <tr><td>44</td><td>Umea</td></tr> <tr><td>45</td><td>Upplands-vasby</td></tr> <tr><td>46</td><td>Uppsala</td></tr> </table>	1	Akersberga	2	Alingsas	3	Angelholm	4	Boras	5	Borlange	6	Eskilstuna	7	Falun	8	Gavle	9	Goteborg	10	Halmstad	11	Helsingborg	12	Jonkoping	13	Kalmar	14	Karlskoga	15	Karlskrona	16	Karlstad	17	Kristianstad	18	Landskrona	19	Lidingo	20	Lidkoping	21	Linkoping	22	Lulea	23	Lund	24	Malmo	25	Marsta	26	Motala	27	Norrkoping	28	Nykoping	29	Orebro	30	Ornskoldsvik	31	Ostersund	32	Pitea	33	Sandviken	34	Skelleftea	35	Skovde	36	Sodertalje	37	Stockholm	38	Sundsvall	39	Tabas	40	Trelleborg	41	Trollhattan	42	Tumba	43	Uddevalla	44	Umea	45	Upplands-vasby	46	Uppsala	
1	Akersberga																																																																																																
2	Alingsas																																																																																																
3	Angelholm																																																																																																
4	Boras																																																																																																
5	Borlange																																																																																																
6	Eskilstuna																																																																																																
7	Falun																																																																																																
8	Gavle																																																																																																
9	Goteborg																																																																																																
10	Halmstad																																																																																																
11	Helsingborg																																																																																																
12	Jonkoping																																																																																																
13	Kalmar																																																																																																
14	Karlskoga																																																																																																
15	Karlskrona																																																																																																
16	Karlstad																																																																																																
17	Kristianstad																																																																																																
18	Landskrona																																																																																																
19	Lidingo																																																																																																
20	Lidkoping																																																																																																
21	Linkoping																																																																																																
22	Lulea																																																																																																
23	Lund																																																																																																
24	Malmo																																																																																																
25	Marsta																																																																																																
26	Motala																																																																																																
27	Norrkoping																																																																																																
28	Nykoping																																																																																																
29	Orebro																																																																																																
30	Ornskoldsvik																																																																																																
31	Ostersund																																																																																																
32	Pitea																																																																																																
33	Sandviken																																																																																																
34	Skelleftea																																																																																																
35	Skovde																																																																																																
36	Sodertalje																																																																																																
37	Stockholm																																																																																																
38	Sundsvall																																																																																																
39	Tabas																																																																																																
40	Trelleborg																																																																																																
41	Trollhattan																																																																																																
42	Tumba																																																																																																
43	Uddevalla																																																																																																
44	Umea																																																																																																
45	Upplands-vasby																																																																																																
46	Uppsala																																																																																																

				47 Vallentuna	
				48 Varberg	
				49 Vasteras	
				50 Vaxjo	
49	Tajikistan	TJK		1 Dushanbe	
				2 Isfara	
				3 Khorug	
				4 Khujand	
				5 Kofarnihon	
				6 Konibodom	
				7 Kulob	
				8 Panjakent	
				9 Qurgonteppa	
				10 Tursunzoda	
				11 Uroteppa	
50	Turkmenistan state	TKM		1 Akdepe	
				2 Annau	
				3 Asgabat	
				4 Baherden	
				5 Balkanabat	
				6 Bayramali	
				7 Boldumsaz	
				8 Buzmeyin	
				9 Dasoguz	
				10 Eloten	
				11 Govurdak	
				12 Gumdag	
				13 Kerki	
				14 Kohne urgenc	
				15 Komsomolsk	
				16 Mari	
				17 Serdar	
				18 Tecen	
				19 Turkmenabat	
				20 Turkmenbasi	
				21 Yilanli	
51	Ukraine	UA		1 Alchevs'k	
				2 Anratsyt	
				3 Artemivs'k	
				4 Berdyans'k	
				5 Berdychiv	
				6 Bila tserkva	
				7 Brovary	
				8 Cherkasy	
				9 Chernihiv	
				10 Chernivtsi	

				11	Chervonohrad	
				12	Dniprodzerzhyns'k	
				13	Dnipropetrovs'k	
				14	Donets'k	
				15	Drohobych	
				16	Druzhkivka	
				17	Feodosiya	
				18	Horlivka	
				19	Ivano-frankivs'k	
				20	Izmayil	
				21	Kalush	
				22	Kam'yanets'-podil's'ky	
				23	Kerch	
				24	Kharkiv	
				25	Khartsyz'k	
				26	Kherson	
				27	Khmel'nyts'ky	
				28	Kirovohrad	
				29	Konotop	
				30	Korosten'	
				31	Kostyantynivka	
				32	Kovel'	
				33	Kramators'k	
				34	Krasnoarmiys'k	
				35	Krasnyy luch	
				36	Kremenchuk	
				37	Kryvyy rih	
				38	Kyyiv	
				39	Lozova	
				40	Luhans'k	
				41	Luts'k	
				42	L'viv	
				43	Lysychans'k	
				44	Makiyivka	
				45	Mariupol'	
				46	Melitopol'	
				47	Mukacheve	
				48	Mykolayiv	
				49	Nikopol'	
				50	Nizhyn	
				51	Novomoskovs'k	
				52	Odesa	
				53	Oleksandriya	
				54	Pavlohrad	
				55	Pervomays'k	
				56	Poltava	

				57 Rivne	
				58 Rubizhne	
				59 Sevastopol'	
				60 Shostka	
				61 Simferopol'	
				62 Slav'yans'k	
				63 Smila	
				64 Stakhanov	
				65 Sums	
				66 Sverdlovs'k	
				67 Syeverodonets'k	
				68 Ternopil'	
				69 Torez	
				70 Uman'	
				71 Uzhhorod	
				72 Vinnytsya	
				73 Yalta	
				74 Yenakiyive	
				75 Yevpatoriya	
				76 Zaporizhzhya	
				77 Zhytomyr	
50	Uzbekistan	UZB		1 Andijon	
				2 Angren	
				3 Asaka	
				4 Bekobod	
				5 Beruni	
				6 Buhoro	
				7 Circik	
				8 Cizah	
				9 Cust	
				10 Denau	
				11 Fargona	
				12 Guliston	
				13 Heva	
				14 Hucayli	
				15 Karsi	
				16 Kattakurgon	
				17 Kogon	
				18 Koson	
				19 Kukon	
				20 Kungirof	
				21 Margilon	
				22 Namangan	
				23 Navoi	
				24 Nukus	
				25 Olmalik	

				26	Sahrihan	
				27	Sahrisabz	
				28	Samarkand	
				29	Tahiatos	
				30	Termiz	
				31	Toskent	
				32	Turtkul	
				33	Urgenc	
				34	Yaniyul	
				35	Zarafson	

Part 8 Technical data

Power supply	24 - 265 V AC/DC
Maximum load current [AC-1]	16 A
Contact	Separated, 1x NO/NC
Clock backup time	6 years*
Display and relay operating time in case of power failure	No
Battery type	2032 (lithium), voltage 3V
Accuracy of the clock indication	1 s
Timing error	±1 s / 24h
Power consumption	< 1,5 W
Connection	Screw terminals 2.5mm ² (wire) / 4mm ² (wire)
Tightening torque	0.5 Nm
Operating temperature	-20 ... +50 C°
Dimensions	2 modules (35 mm)
Assembly	TH-35 rail
Degree of protection	IP20

(*) Battery life depends on the operating conditions and how long the clock is powered from the battery only. Low ambient temperatures severely limit battery life.

Part 9: History of change

Date	Version	Description
2022.05.04	1.0.0	First version of the manual
2022.09.06	1.0.1	Improving the device index

Part 10 Warranty

1. The controller is covered by a 24-month warranty. The warranty period is calculated from the date of delivery.
2. The guarantee is only valid with proof of purchase.
3. Claims must be made at the point of purchase or directly with the manufacturer:

F&F Filipowski sp. j.
79/81 Konstantynowska St.
95-200 Pabianice
Tel: (42) 227-09 71
e-mai: dztech@fif.com.pl

4. The complaint must be accompanied by written information on the nature of the defect and the circumstances in which it occurred.
5. F&F Filipowski sp. j. undertakes to handle complaints in accordance with the provisions of Polish law.
6. It is up to the manufacturer to choose how to deal with the complaint: replacement with defect-free goods, repair or refund.
7. The guarantee does not cover:
 - a. Mechanical and chemical damage
 - b. Damage caused by incorrect or non-compliant use
 - c. Damage occurring after the sale as a result of accidents or other events for which neither the manufacturer nor the retailer is responsible, e.g.: damage during transport.
8. The guarantee does not cover operations which, according to the instructions, should be carried out by the user, e.g.: installation of the multimeter, electrical installation, installation of other required electrical safety devices.
9. The guarantee does not limit the rights of the buyer resulting from the non-conformity of the goods with the contract.

Part 11 CE declaration

F&F Filipowski sp. j. declares that the equipment complies with the requirements of Directive 2014/53/EU of the European Parliament and of the Council of 16 April 2014 on the harmonisation of the laws of the Member States relating to making radio equipment available on the market and repealing Directive 1999/5/EC. The CE Declaration of Conformity, together with references to the standards against which conformity is declared, can be found at: www.fif.com.pl on the product subpage.